

CCD Cameras

Venuslab ExView U3 Camera

Covers bright-field, low-light & fluorescence microscopy.

- Adopts Sony ExView HAD CCD chip
- Supports a maximum exposure time of 1 hour
- USB 3.0 (5Gbps) high-speed interface
- Integrated CNC aluminum alloy housing
- Multi-platform SDK (Windows/Linux/macOS/Android)



One Platform Many Possibilities

Contact Us sales@venuslabtech.com

Get a Quote



Get Expert Advice
+658099 5547 (WhatsApp)



Visit Us
www.venuslabtech.com

Overview

Introduction:

The Sony ExView HAD CCD incorporates a technology that converts unconverted near-infrared light into image signals, thereby extending the imaging spectrum from visible light to near-infrared light. This technology greatly enhances the light sensitivity of the sensor. When using the "ExView HAD CCD" chip, high-brightness images can still be obtained in dark environments. Furthermore, the diffused light that previously leaked into the vertical CCD section during photoelectric conversion in the deep layers of the silicon wafer can now be captured by the sensor, thus significantly reducing the sensor's noise.

Features:

- C-mount CCD camera featuring SONY ExView technology
- Integrated CNC aluminum alloy housing
- FPGA-controlled precise exposure (max. 1h) for weak fluorescence imaging.
- USB 3.0 (5Gbit/s) interface for high video transmission speed
- Ultra-Fine color engine for accurate color reproduction
- Advanced video and image processing software included with the camera
- Standard SDKs provided for multiple platforms: Windows, Linux, macOS, and Android

Dimension:

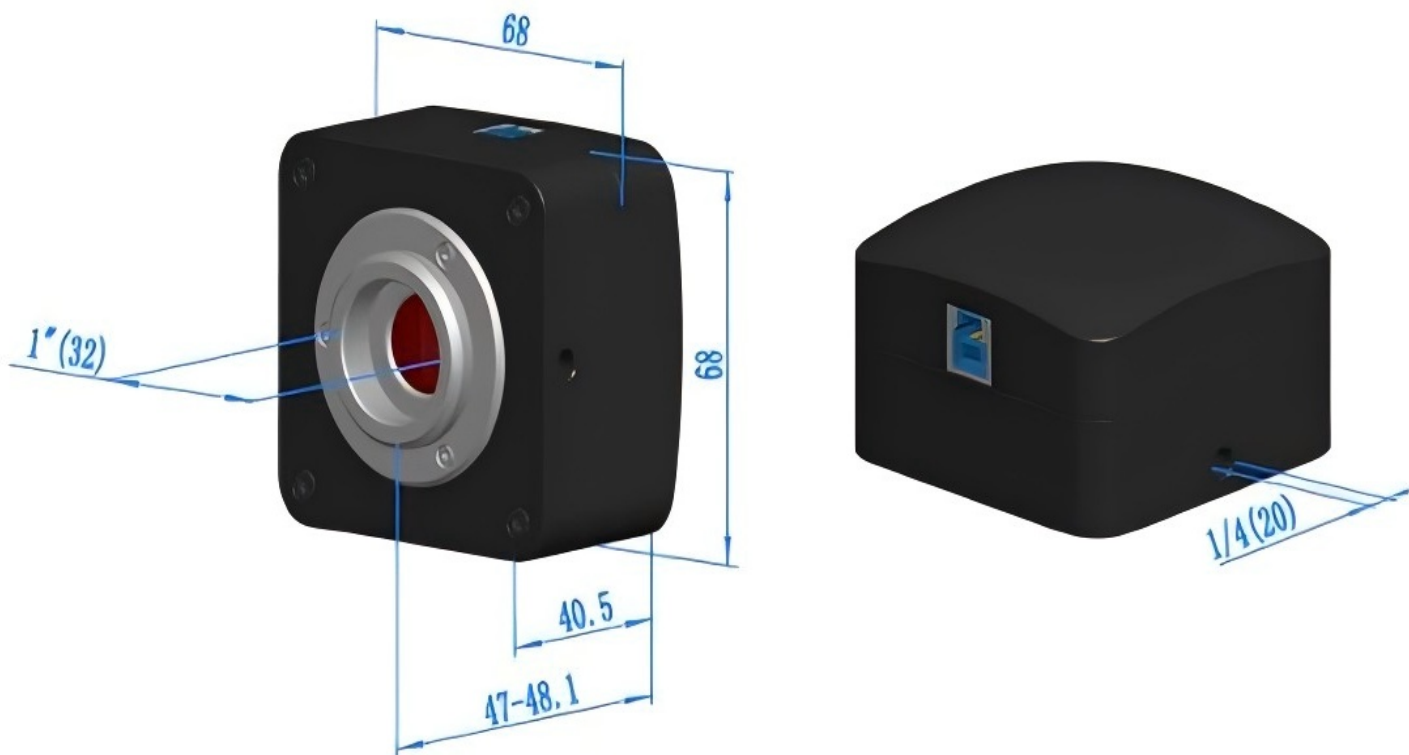

Specifications

Common Parameter Specification Table

Hardware Configuration	
Spectral Response Range	380– 650nm (with an infrared cut-off filter installed)
White Balance	ROI white balance (manual Temp-Tint adjustment)
Color Reproduction Tech	Ultra-Fine Color Processing Engine
Capture Control SDK	Multi-platform SDK (Windows/Linux/macOS/Android) supporting Native C++ , C#/VB.NET, Python, Java, DirectShow, Twain, etc.
Bit Depth	8 Bit / 14 Bit
Recording Modes	Images and Video
Cooling Method	Passive Cooling
Camera Operating Environment	
Operating Temperature	-10°C ~ 50°C
Storage Temperature	-20°C ~ 60°C
Operating Humidity	30~80%RH
Storage Humidity	10~60%RH
Power Supply	Camera powered via USB 3.0 interface
Software Operating Environment	
Operating System	Microsoft® Windows® XP/Vista / 7 / 8 / 10 / 11 (32 & 64-bit); OS X (Mac OSX)
Computer Configuration	CPU: Intel Core 2 2.8GHz or higher
	Memory: 2GB or more
	USB Port: USB 3.0 high-speed port (USB 2.0 port required)
	Display: 17" or larger
	CD-ROM: Required

Packing List

Packing Information for Venuslab ExView U3 Series



Standard Packaging List			
A	Shipping carton specification: L: 52cm, W: 32cm, H: 32cm (20pcs, 17Kg/carton), not shown in the above figure.		
B	Package box specification: L: 15cm, W: 15cm, H: 10cm (0.7 – 0.75kg per box).		
C	One U3CCD series camera.		
D	High-speed USB 3.0 A-to-B gold-plated data cable, 2.0m.		
E	CD (driver and application software, ?12cm).		
Optional Accessories			
F	Adjustable-focus eyepiece adapter	Dia. 23.2mm eyepiece tube to C-mount (Choose one based on your camera/microscope)	108001/AMA037108002/ AMA050108003/ AMA075108004/ AMA100
		Dia. 31.75mm eyepiece tube to C-mount (Choose one based on your camera/telescope)	108008/ATA037108009/ ATA050108010/ ATA075108011/ATA100
G	Fixed eyepiece adapter	Dia. 23.2mm eyepiece tube to C-mount (Choose one based on your camera/microscope)	108005/FMA037108006/ FMA050108007/ FMA075108008/FMA100
		Dia. 31.75mm eyepiece tube to C-mount (Choose one based on your camera/telescope)	108011/FTA037108012/ FTA050108013/ FTA075108014/FTA100
For options F & G, confirm your camera model (C-mount, microscope/telescope camera first). VenusLab engineers will assist selection based on your application.			
H	108015 (Dia. 23.2mm 30.0mm adapter) / For 30.0mm-diameter eyepiece tube adapter ring.		
I	108016 (Dia. 23.2mm 30.5mm adapter) / For 30.5mm-diameter eyepiece tube adapter ring.		
J	108017 (Dia. 23.2mm 31.75mm adapter) / For 31.75mm-diameter eyepiece tube adapter ring.		
K	Microruler	106011/TS-M1(X=0.01mm/100Div.);106012/TS-M2(X,Y=0.01mm/100Div.);106013/TS-M7 (X=0.01mm/100Div.,0.10mm/100Div.)	

Service & Support

We are dedicated to delivering exceptional optoelectronic solutions to every client. From precision manufacturing and secure delivery to full-lifecycle technical support, we are here to ensure a seamless and reliable experience at every step.

1. Warranty Policy

Quality First, Worry-Free Operation

Warranty Period: We offer a **two-year** warranty service for all of our core optoelectronic products, effective from the date of shipment.

Coverage: We provide free repair or replacement services for malfunctions caused by material defects or workmanship errors under normal operating conditions.

Rapid Response: Upon receiving a warranty claim, we guarantee to initiate the assessment process within **24 hours** to minimize your equipment downtime.

2. Technical Support

Expert Team, Full-Process Guidance

Technical Consultation: Our team of senior optical engineers provides **24/7 online support** to assist with installation, commissioning, optical path alignment, and parameter optimization.

Scheduled Maintenance: We offer full-lifecycle maintenance recommendations, including firmware upgrades, optical component cleaning guidelines, and precision calibration services.

Training Services: We provide customized remote or on-site operational and safety training to ensure your team can operate the equipment efficiently and safely.

3. Logistics & Delivery

Precision Packaging, Global Reach

Professional Packaging: Given the fragile nature of optical instruments, we utilize industrial-grade shockproof, anti-static, and moisture-proof vacuum packaging to ensure zero damage during transit.

Logistics Partners: We partner with top-tier global logistics providers (**DHL / FedEx / UPS / SF Express**) to offer reliable shipping with real-time tracking.

Shipping Insurance: All shipments are fully insured to eliminate logistics risks.

4. Compliance & Certification

Strict Standards, Total Compliance

Quality Certification: Our manufacturing process is **ISO 9001 certified**, and our products comply with international standards such as **CE** and **RoHS**.

Export Compliance: "Committed to environmental responsibility, all our products comply with **RoHS 2.0** and **REACH** standards, ensuring safety and global compliance."

Explore Series

Model	Green Light Sensitivity & Dark Current	Sensor Model and Size	Exposure Time	Sampling Averaging	FPS/Resolution	Pixel Pitch (µm)
NP112000A	420mv with 1/30s 15.2mv with 1/30s	12M/ICX834AQG (C) 1 " (13.15x8.77)	0.06ms~ 1000s	1x1 2x2	3.6@ 4248x2836 3.6@ 2124x1418	3.1x3.1
NM112000A	420mv with 1/30s 12mv with 1/30s (F8.0)	12M/ICX834ALG (M) 1 " (13.15x8.77)	0.06ms~ 1000s	1x1 2x2	3.6@ 4248x2836 3.6@ 2124x1418	3.1x3.1
NP109000A	580mv with 1/30s 12mv with 1/30s	9.0M/ICX814AQG (C) 1 " (12.47x9.98)	0.06ms~ 1000s	1x1 2x2	4.4@ 3388x2712 4.4@ 1694x1356	3.69x3.69
NM109000A	660mv with 1/30s 12mv with 1/30s (F8.0)	9.0M/ICX814ALG (M) 1 " (12.47x9.98)	0.06ms~ 1000s	1x1 2x2	4.4@ 3388x2712 4.4@ 1694x1356	3.69x3.69
NP106000A	880mv with 1/30s 8mv with 1/30s	6.0M/ICX694AQG (C) 1 " (12.48x9.99)	0.06ms~ 1000s	1x1	7.5@ 2748x2200 14@ 2748x1092	4.54x4.54
NM106000A	1000mv with 1/30s 8mv with 1/30s	6.0M/ICX694ALG (M) 1 " (12.48x9.99)	0.06ms~ 1000s	1x1	7.5@ 2748x2200 14@ 2748x1092	4.54x4.54
NP102800A	800mv with 1/30s 4mv with 1/30s	2.8M/ICX674AQG (C) 2/3 " (8.81x6.63)	0.05ms~ 1000s	1x1	15@ 1938x1460 17@ 1610x1212 18@ 1930x1092	4.54x4.54
NM102800A	950mv with 1/30s 4mv with 1/30s	2.8M/ICX674ALG (M) 2/3 " (8.81x6.63)	0.05ms~ 1000s	1x1	15@ 1938x1460 17@ 1610x1212 18@ 1930x1092	4.54x4.54
NP101400B	2000mv with 1/30s 4.8mv with 1/30s	1.4M/ICX825AQA (C) 2/3 " (8.88x6.70)	0.07ms~ 1000s	1x1	25@ 1376x1040	6.45x6.45
NM101400B	2000mv with 1/30s 4.8mv with 1/30s	1.4M/ICX825ALA (M) 2/3 " (8.88x6.70)	0.07ms~ 1000s	1x1	25@ 1376x1040	6.45x6.45

 Get in touch with our team to explore configurations, request a quote, or learn more about customized solutions tailored to your needs.

Let us help you move science forward—faster and smarter.

[Get a Quote](#)



Get Expert Advice
+658099 5547 (WhatsApp)



Visit Us
www.venuslabtech.com