

# Spectroscopy Systems

## Field Pro Spectrometer

"High-precision + Portable + Full-scene" professional-grade ground object spectral detection

- High-precision optical performance
- Full-scene portable adaptation
- The software and hardware are deeply coordinated
- High customization and expandability

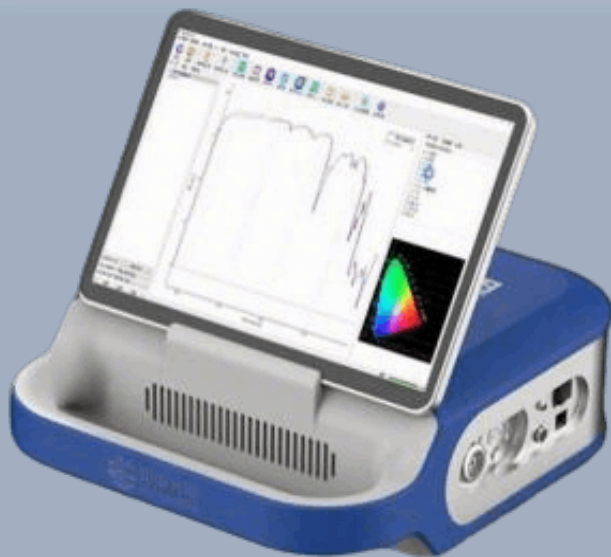

One Platform Many Possibilities

Contact Us [sales@venuslabtech.com](mailto:sales@venuslabtech.com)

Get a Quote



Get Expert Advice  
+658099 5547 ( WhatsApp )



Visit Us  
[www.venuslabtech.com](http://www.venuslabtech.com)

## Overview

### Introduction:

The Field Pro Spectrometers are a wide-spectrum on-site detection system independently developed by Venuslab. Their core positioning is a "portable, high-precision ground object spectral measurement tool", specially designed for on-site detection in fields such as soil, minerals, crops, water quality, and forestry ecology. They can replace traditional "bulky, large, and clumsy" laboratory spectrometers, enabling rapid sampling inspections in scenarios such as the wild and construction sites, without the need for sample preparation and submission procedures. Currently, the series includes three models: VL-Field1100, VL-Field1700, and VL-Field2500, covering different spectral measurement needs.

### Features:

- High resolution and sensitivity
- Stable optical transmission
- Strong outdoor endurance and protection
- No sample preparation required
- Data closed-loop processing
- Low-threshold operation
- Customization of wavelength range
- Flexible expansion of accessories

### Dimension:

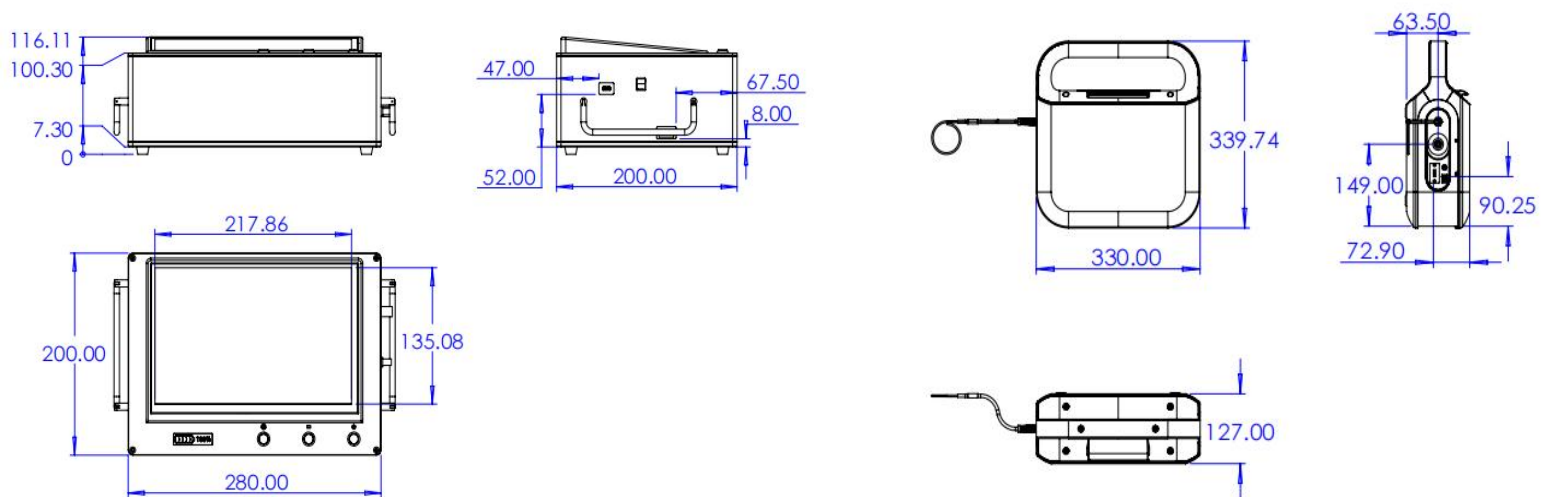

VL-Field1100

VL-Field2500

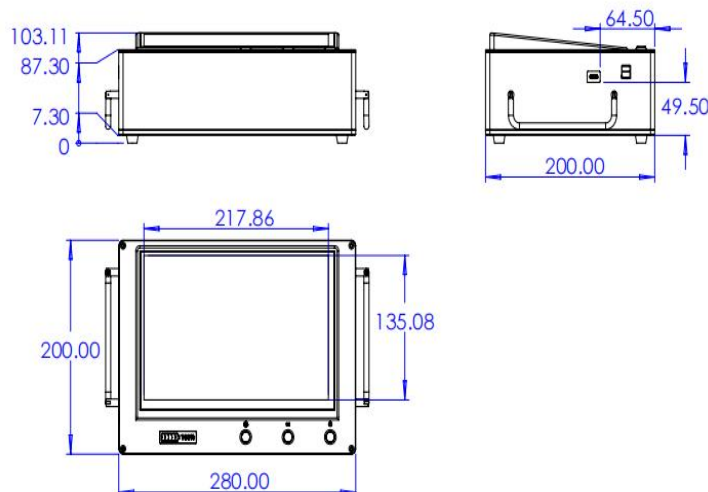

VL-Field1700

## Specifications

### Common Parameter Specification Table

Specification Parameter	Value / Description
Wavelength Accuracy	0.5nm
Stray Light Proportion	0.1%
Wavelength Repeatability	0.2nm
Integration Time Range	60μs - 65s (partial bands support 100μs - 50ms)
Communication Interfaces	Supports Bluetooth, USB, WIFI, GPS multi-protocol communication
Operating Temperature Range	0°C - 40°C
Storage Temperature Range	-15°C - 45°C
Standard Power Adapter Parameters	12V/3A
Optional Mobile Power Parameters	24V/12V specification, 35000mAh capacity (supports long...)

## Accessories List

### Main Accessories List

Accessory Name	Specification/Description
Main Unit	Field spectrometer host with integrated control module and display screen.
Spectral Probe	Reflectance probe with built-in full-spectrum tungsten halogen lamp (no extra light source required).
Power Adapter	Standard power adapter, 12V/3A.
Mobile Power Supply	Optional mobile power supply, 24V/12V, 35000mAh (supports long endurance for field operation).
Data Cable	USB cable for data transmission and device connection.
Calibration Diffuse Reflection White Board	Diffuse reflection white board (reflectance 97% in visible range, optional).
Leaf Measurement Clip	PTFE leaf clip (for plant leaf measurement, optional).
Narrow FOV Lens	Optional lens with field-of-view angle of 1°– 10° (for small sample measurement).
Specialized Software	Pre-installed software specialized in field spectroscopy measurement and data analysis.
Carrying Case	Portable backpack for convenient transportation of the entire system.

## Interface Definition

### Interface Definition Table

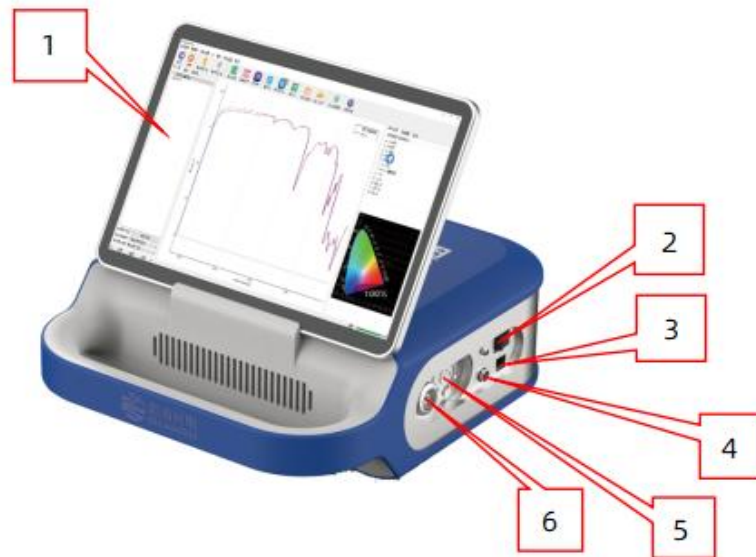

No.	Interface Name	Interface Description
1	Pad Display Screen	A touchscreen Pad display used for device operation, parameter setting, and measurement data display.
2	Ground Object Host Power Switch	A physical switch that controls the activation and deactivation of the ground object spectrometer host.
3	USB Communication Port	An interface that enables data transmission and communication connection between the ground object spectrometer host and the Pad.
4	Ground Object Host Power Port	An interface used to connect a 12V/3A power adapter or mobile power supply to provide working power for the ground object spectrometer host.
5	Ground Object Probe Power Port	An interface used to connect the probe power cable and provide working power for the ground object reflective probe.
6	Probe Optical Fiber Interface	An interface used to connect the optical fiber of the ground object reflective probe, with the interface specification of SMA905.

## Service & Support

We are dedicated to delivering exceptional optoelectronic solutions to every client. From precision manufacturing and secure delivery to full-lifecycle technical support, we are here to ensure a seamless and reliable experience at every step.

### 1. Warranty Policy

#### Quality First, Worry-Free Operation

**Warranty Period:** We offer a **two-year** warranty service for all of our core optoelectronic products, effective from the date of shipment.

**Coverage:** We provide free repair or replacement services for malfunctions caused by material defects or workmanship errors under normal operating conditions.

**Rapid Response:** Upon receiving a warranty claim, we guarantee to initiate the assessment process within **24 hours** to minimize your equipment downtime.

## 2. Technical Support

### Expert Team, Full-Process Guidance

**Technical Consultation:** Our team of senior optical engineers provides **24/7 online support** to assist with installation, commissioning, optical path alignment, and parameter optimization.

**Scheduled Maintenance:** We offer full-lifecycle maintenance recommendations, including firmware upgrades, optical component cleaning guidelines, and precision calibration services.

**Training Services:** We provide customized remote or on-site operational and safety training to ensure your team can operate the equipment efficiently and safely.

## 3. Logistics & Delivery

### Precision Packaging, Global Reach

**Professional Packaging:** Given the fragile nature of optical instruments, we utilize industrial-grade shockproof, anti-static, and moisture-proof vacuum packaging to ensure zero damage during transit.

**Logistics Partners:** We partner with top-tier global logistics providers (**DHL / FedEx / UPS / SF Express**) to offer reliable shipping with real-time tracking.

**Shipping Insurance:** All shipments are fully insured to eliminate logistics risks.

## 4. Compliance & Certification

### Strict Standards, Total Compliance

**Quality Certification:** Our manufacturing process is **ISO 9001 certified**, and our products comply with international standards such as **CE** and **RoHS**.

**Export Compliance:** "Committed to environmental responsibility, all our products comply with **RoHS 2.0** and **REACH** standards, ensuring safety and global compliance."

## Explore Series

Model	Resolution (Typical Value)	Standard Wavelength Range (Customizable)	Integration Time Range	Weight
VL-Field 1100	2.5 nm @ 350-1100 nm	350-1100 nm	60 $\mu$ s - 65 s @ 350-1100 nm	5.44 kg
VL-Field 1700	2.5 nm @ 350-950 nm; 8.0 nm @ 950-1700 nm	350-1700 nm	60 $\mu$ s - 65 s @ 350-950 nm; 100 $\mu$ s - 5 s @ 950-1700 nm	5.44 kg
VL-Field 2500	2.5 nm @ 350-950 nm; 8.0 nm @ 950-2500 nm	350-2500 nm	60 $\mu$ s - 65 s @ 350-950 nm; 100 $\mu$ s - 50 ms @ 950-2500 nm	5.44 kg

 Get in touch with our team to explore configurations, request a quote, or learn more about customized solutions tailored to your needs.

Let us help you move science forward—faster and smarter.

[Get a Quote](#)



Get Expert Advice  
+658099 5547 ( WhatsApp )



Visit Us  
[www.venuslabtech.com](http://www.venuslabtech.com)