

# CMOS Cameras

## Venuslab-ISP CMOS Camera

Balances professional performance with high cost-effectiveness.

- Hardware-level image processing engine
- High optical performance
- High-sensitivity and low-noise imaging
- Full-scenario compatibility design
- Balance between high resolution and transmission efficiency



One Platform Many Possibilities

Contact Us [sales@venuslabtech.com](mailto:sales@venuslabtech.com)

Get a Quote



Get Expert Advice  
+658099 5547 ( WhatsApp )



Visit Us  
[www.venuslabtech.com](http://www.venuslabtech.com)

## Overview

### Introduction:

**1. Professional Performance:** Focusing on the core needs of microscopic imaging, with technical parameters benchmarking against scientific research-grade standards

Equipped with Sony Exmor, Exmor R/RS back-illuminated CMOS sensors, it adopts dual-layer noise reduction technology, with a minimum dark current of only 0.03mV (such as Venuslab-ISP45KP-B,) and a maximum G-light sensitivity of 5970mV/lux · s (Venuslab-ISP08KP-D). It can capture clear details in low-light and fluorescence imaging scenarios (such as live cell observation and GFP analysis), meeting the strict noise control requirements of scientific research-grade imaging.

The resolution ranges from 1.5 million to 45 million pixels. The top model, Venuslab-ISP45KP-A, can output ultra-high-definition images with a resolution of 8176×5616, which is suitable for observing precise structures under high-power microscopes (such as 100× objective lenses), such as semiconductor defect detection.

It integrates a 12-bit Ultra-fine™ hardware image signal processor (HISP VP), which can hardware-accelerate tasks such as Demosaic conversion, automatic exposure, ROI white balance, and gamma correction. Traditional software processing requires more than 50% of the computer's CPU resources, while this series, through hardware acceleration, enables 21-megapixel models to reach a frame rate of 17fps (Section 9.2.2), and 45-megapixel models to still maintain 8.1fps. It balances high resolution and real-time preview, avoiding the industry pain point of "high pixels leading to low frame rates".

**2.High cost performance:** Uncompromised performance, more controllable costs, balancing professional needs and procurement budgets. It adopts a CNC zinc-aluminum alloy shell and a structure without moving parts (avoiding failure points such as lens displacement and fan jitter), which not only reduces manufacturing costs but also improves long-term usage stability (the mean time between failures is 30% higher than that of models with moving parts). The front end is standard-equipped with an IR-CUT filter or dual AR coating, eliminating the need for users to purchase additional optical accessories and reducing subsequent investments.

The series covers multiple resolution ranges from 1.5 million (Venuslab-ISP01KP-A) to 45 million (Venuslab-ISP45KP-A). For teaching demonstrations and routine pathological testing, models with 1.5 to 5 million pixels can be selected; for precision scientific research, models with more than 20 million pixels are suitable. This avoids "paying a premium for unnecessary high pixels" and meets professional needs under different budgets.

### Features:

- High-quality imaging hardware
- Hardware ISP efficient processing
- Strong compatibility design
- Durable and low-cost

### Dimension:

The Venuslab-ISPseries body, made from tough, CNC aluminum alloy, ensures a heavy duty, workhorse solution. The camera is designed with a high quality IR-CUT to protect the camera sensor. No moving parts included. This design ensures a rugged, robust solution with an increased lifespan when compared to other industrial camera solutions.

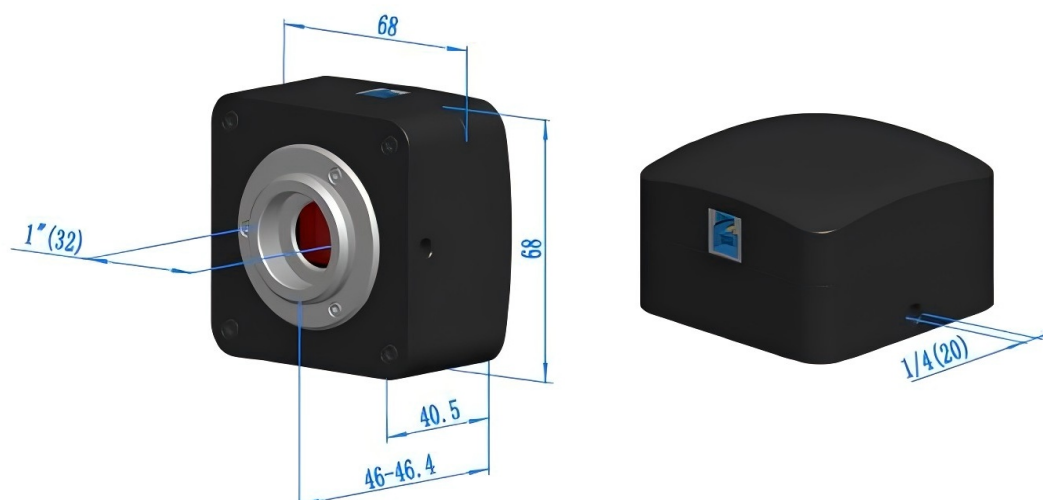

## Specifications

Common Parameter Specification Table

Other Specification	
Spectral Range	380-650nm(with IR-cut Filter)
White Balance	ROI White Balance/Manual Temp Tint Adjustment/NA for Monochromatic Sensor
Color Technique	Ultra-Fine HISPVP/NA for Monochromatic Sensor
Capture/Control SDK	Windows/Linux/macOS/Android Multiple Platform SDK(Native C/C++ ,C# VB.NET,Python,Java,DirectShow,Twain,etc)
ADC	8 Bit/12 Bit
Recording System	Still Picture and Movie
Cooling System*	Natural
Operating Environment	
Operating Temperature(in Centidegree)	-10~50
Storage Temperature(in Centidegree)	-20~60
Operating Humidity	30~80%RH
Storage Humidity	10~60%RH
Power Supply	DC 5Vover PC USB3.0 Port.Compatible with USB2.0
Software Environment	
Operating System	Microsof@WindowsXP/Vista/7/8/10/11(32&64 bit)OSx(Mac OSX) Linux
PC Requirements	CPU:Equal to Intel Core22.8GHz or Higher
	Memory:2GB or More
	USB Port:USB3.0 High-speed Port
	Display:17" or Larger
	CD-ROM

## Packing List

Packing Information for Venuslab-ISP Series



Standard Camera Packing List	
A	Carton L:52cm W:32cm H:33cm(20pcs,12~17Kg/carton),not shown in the photo
B	Gift boxL:15cm W:15cm H:10cm(0.58~0.6Kg/box)
C	One Venuslab-ISP series camera
D	High-speed USB3.0Amale to B male gold-plated connectors cable /2.0m
E	CD(Driver &utilities software,Ø12cm)

Optional Accessory			
F	Adjustable lens adapter	C-mount to Dia.23.2mm eyepiece tube(Please choose 1 of them for your microscope)	108001/AMA037108002/ AMA050108003/ AMA075108004/AMA100
		C-mount to Dia.31.75mm eyepiece tube (Please choose 1 of them for your telescope)	108008/ATA037108009/ ATA050108010/ ATA075108011/ATA100
G	Fixed lens adapter	C-mount to Dia.23.2mm eyepiece tube(Please choose 1 of them for your microscope)	108005/FMA037108006/ FMA050108007/ FMA075108008/FMA100
		C-Mount to Dia.31.75mm eyepiece tube (Please choose 1 of them for your telescope)	108011/FTA037108012/ FTA050108013/ FTA075108014/FTA100
Note.For F and G optional items,please specify your camera type(C-mount,microscope camera or telescope camera ),Venuslab engineer will help you toldetermine the right microscope or telescope camera adapter for your application ;			
H	08015(Dia.23.2mm to 30.0mm ring)/Adapter rings for 30mm eyepiece tube		
I	108016(Dia.23.2mm to 30.5mm ring)/Adapter rings for 30.5mm eyepiece tube		
J	08017(Dia.23.2mm to 31.75mm Ring)/Adapter rings for 31.75mm eyepiece tube		
K	Calibration kit	106011/TS-M1(X=0.01mm/100Div.);106012/TS-M2(X,Y=0.01mm/100Div.); 106013/TS-M7(X=0.01mm/100Div.,0.10mm/100Div.)	

## Applications

Fluorescence Captured by Venuslab-ISP08KP-C (Zeiss, 40x, BPAE cells)

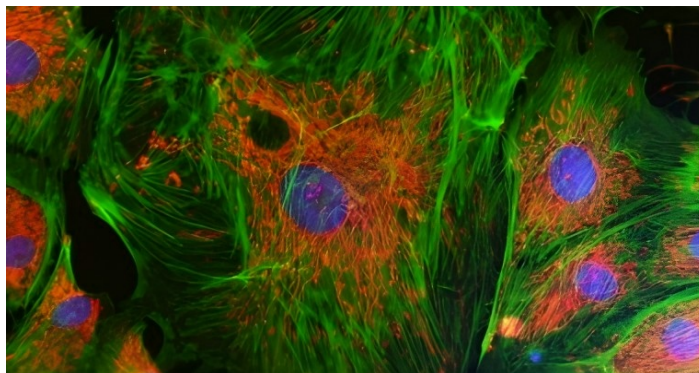

Fluorescence Captured by Venuslab-ISP08KP-C (Zeiss, 10x, BPAE cells)

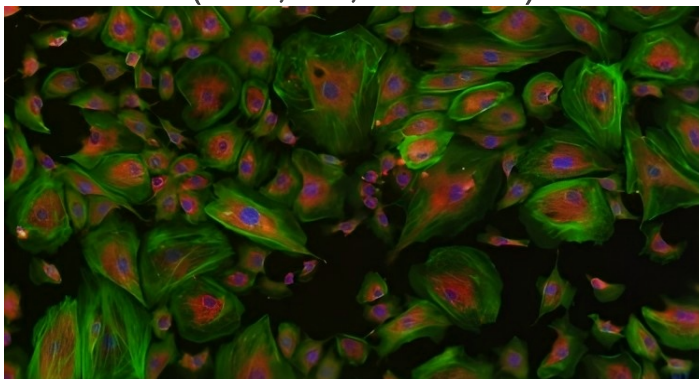

## Service & Support

We are dedicated to delivering exceptional optoelectronic solutions to every client. From precision manufacturing and secure delivery to full-lifecycle technical support, we are here to ensure a seamless and reliable experience at every step.

### 1. Warranty Policy

#### Quality First, Worry-Free Operation

**Warranty Period:** We offer a **two-year** warranty service for all of our core optoelectronic products, effective from the date of shipment.

**Coverage:** We provide free repair or replacement services for malfunctions caused by material defects or workmanship errors under normal operating conditions.

**Rapid Response:** Upon receiving a warranty claim, we guarantee to initiate the assessment process within **24 hours** to minimize your equipment downtime.

### 2. Technical Support

#### Expert Team, Full-Process Guidance

**Technical Consultation:** Our team of senior optical engineers provides **24/7 online support** to assist with installation, commissioning, optical path alignment, and parameter optimization.

**Scheduled Maintenance:** We offer full-lifecycle maintenance recommendations, including firmware upgrades, optical component cleaning guidelines, and precision calibration services.

**Training Services:** We provide customized remote or on-site operational and safety training to ensure your team can operate the equipment efficiently and safely.

### 3. Logistics & Delivery

#### Precision Packaging, Global Reach

**Professional Packaging:** Given the fragile nature of optical instruments, we utilize industrial-grade shockproof, anti-static, and moisture-proof vacuum packaging to ensure zero damage during transit.

**Logistics Partners:** We partner with top-tier global logistics providers (**DHL / FedEx / UPS / SF Express**) to offer reliable shipping with real-time tracking.

**Shipping Insurance:** All shipments are fully insured to eliminate logistics risks.

### 4. Compliance & Certification

#### Strict Standards, Total Compliance

**Quality Certification:** Our manufacturing process is **ISO 9001 certified**, and our products comply with international standards such as **CE** and **RoHS**.

**Export Compliance:** "Committed to environmental responsibility, all our products comply with **RoHS 2.0** and **REACH** standards, ensuring safety and global compliance."

## Explore Series

Model	Binning	Pixel(μm)	G Sensitivity / Dark Signal	Exposure	FPS/Resolution	Sensor & Size(mm)
Venuslab-ISP45KP-A	1x1(3:2) 2x2(3:2) 1x1(4:3) 2x2(4:3) 1x1(17:9) 2x2(17:9) 3x3(17:9) 4x4(17:9)	2.315x2.315	108mv with 1/30s 0.03mv with 1/30s	0.1ms~15s	8.1@8176x5616 30.0@4088x2808 8.1@7408x5556 33.0@4088x2808 10.4@8176x4320 34.7@4096x2160 62.5@2048x1080 86.5@1344x720	45M/IMX294 (C)1.4" (18.93x13.00)
Venuslab-ISP45KP-B	1x1(3:2) 2x2(3:2) 1x1(4:3) 2x2(4:3) 1x1(17:9) 2x2(17:9) 3x3(17:9) 4x4(17:9)	2.315x2.315	108mv with 1/30s 0.03mv with 1/30s	0.1ms~15s	8.1@8176x5616(C) 30.0@4080x2808(M) 8.1@7408x5556(C) 33.0@3696x2778(M) 10.4@8176x4320(C) 34.7@4096x2160(M) 62.5@2048x1080(M) 86.5@1344x720(M)	45M/IMX492 (C,RS)1.4" (18.93x13.00)
Venuslab-ISP32KP-A	1x1 2x2 4x4	2.315x2.315	108mv with 1/30s 0.03mv with 1/30s	0.1ms~15s	8.1@5600x5600 30.0@2800x2800 30.0@1400x1400	32M/IMX294 (C)1.15" (12.96x12.96)
Venuslab-ISP25KP-A	1x1 2x2 3x3	1.12x1.12	96.3mv with 1/30s 0.1mv with 1/30s	0.013ms~15s	12@4928x4928 46@2464x2464 100@1648x1648	25M/IMX511 (C)1/2.3" (5.519x5.519)
Venuslab-ISP21KP-A	1x1 1x1 2x2 3x3 9x9	3.3 x3.3	399mv with 1/30s 0.1mv with 1/30s	0.1ms~15s	17@5280x3954 17@3952x3952 17@2640x1976 17@1760x1316 192@584x438	21M/IMX269 (C) 4/3"(17.4x13.0)
Venuslab-ISP20.4KP-A	1x1 2x2 4x4	2.74 x2.74	1574mv with 1/30s 0.15mv with 1/30s	0.03ms~15s	17.5@4496x4496 64.4@2240x2240 64.4@1120x1120	20.4M/IMX541(C,GS)1.1" (12.32x12.32)
Venuslab-ISP20KP-A	1x1 2x2 3x3	2.4 x2.4	462mv with 1/30s 0.21mv with 1/30s	0.1ms~15s	15@5440x3648 50@2736x1824 60@1824x1216	20M/IMX183 (C,RS) 1"(13.06x8.76)
Venuslab-ISP20KP-C	1x1 2x2 3x3	2.4 x2.4	462mv with 1/30s 0.21mv with 1/30s	0.1ms~15s	20@5440x3648 48@2736x1824 58@1824x1216	20M/IMX183 (C,RS) 1"(13.06x8.76)
Venuslab-ISP15.6KP-A	1x1 2x2 3x3	3.3 x3.3	399mv with 1/30s 0.1mv with 1/30s	0.1ms~15s	17@3952x3952 17@1976x1976 17@1316x1316	15.6M/SONY Special(C)1.1" (13.0x13.0)
Venuslab-ISP18KP-A	1x1 2x2 3x3	1.2 x1.2	130mv with 1/30s 0.1mv with 1/30s	0.1ms~15s	17@4880x3720 40@2448x1836 50@1728x1296	18M/SONY Special(C) 1/2.2 "(5.86x4.46)

Venuslab-ISP12.4KP-A	1x1 2x2 4x4	2.74 x2.74	1337mv with 1/30s 0.15mv with 1/30s	0.03ms~15s	28.2@4096x3000 100.9@2048x1500 100.9@1024x750	12.4M/IMX545 (C, GS) 1/1.1" (11.22x8.22)
Venuslab-ISP12.3KP-A	1x1 1x1	3.45x3.45	1146mv with 1/30s 0.1mv with 1/30s	0.244ms~15s	23.4@4096x3000 46.3@2048x1500	12.3M/IMX304(C, GS) 1.1" (14.13x10.35)
Venuslab-ISP12KP-A	1x1 2x2	1.85x1.85	280mv with 1/30s 0.1mv with 1/30s	0.1ms~15s	25@4000x3000 50@2048x1080	12M/IMX226 (C) 1/1.7" (7.40x5.55)
Venuslab-ISP12KP-B	1x1 2x2 4x4	1.55x1.55	250mv with 1/30s 0.25mv with 1/30s	0.1ms~5s	30@4056x3040 60@2028x1520 120@1014x760	12M/IMX577 (C) 1/2" (6.29x4.71)
Venuslab-ISP12KP-C	1x1 2x2	2.0x2.0	3637mv with 12 bit converted value(HCG) 0.15mv with 1/30s	0.013ms~15s	27@3536x3536 60@1768x1768	12M/IMX676 (C) 1/1.6" (7.07x7.07)
Venuslab-ISP90KP-A	1x1 1x1	3.45x3.45	1146mv with 1/30s 0.15mv with 1/30s	0.1ms~15s	34@4096x2160 60@2048x1080	9.0M/IMX305 (C, GS) 1" (14.13x7.45)
Venuslab-ISP90KP-B	1x1 2x2 3x3	3.76x3.76	535mv with 1/30s 0.04mv with 1/30s	0.1ms~15s	40@3008x3000 123@1488x1500 186@992x998	9.0M/IMX533 (C) 1" (11.31x11.28)
Venuslab-ISP8.3KP-A	1x1 2x2	1.62x1.62	236mv with 1/30s 0.1mv with 1/30s	0.244ms~15s	32@3840x2160 65@1920x1080	8.3M/IMX274 (C) 1/2.5" (6.22x3.50)
Venuslab-ISP8.3KP-B	1x1 2x2	2.0x2.0	505mv with 1/30s 0.1mv with 1/30s	0.02ms~15s	35@3840x2160 60@1920x1080	8.3M/IMX334 (C) 1/1.8" (7.68x4.32)
Venuslab-ISP8.3KP-C	1x1 2x2	2.9x2.9	2188mv with 1/30s 0.15mv with 1/30s	0.02ms~15s	45@3840x2160 70@1920x1080	8.3M/IMX485 (C) 1/1.2" (11.14x6.26)
Venuslab-ISP8.3KP-D	1x1 2x2	2.9x2.9	5970(mV/lx/s) 0.13mv with 1/30s	0.02ms~15s	45@3840x2160 70@1920x1080	8.3M/IMX585 (C) 1/1.2" (11.14x6.26)
Venuslab-ISP8.3KP-E	1x1 2x2	2.0x2.0	3541(mV/lx/s) 0.15mv with 1/30s	0.02ms~15s	45@3840x2160 70@1920x1080	8.3M/IMX678 (C) 1/1.8" (7.68x4.32)
Venuslab-ISP8.0KP-A	1x1 2x2 4x4	4.63 x4.63	419mv with 1/30s 0.12mv with 1/30s	0.1ms~15s	30@2808x2808(14bit) 139@1392x1392 139@696x696	8.0M/IMX294 (C) 1.15"(13.00x13.00)

Venuslab-ISP6.3KP-A	1x1 2x2	2.4x2.4	425mv with 1/30s 0.15mv with 1/30s	0.1ms~15s	30@3072 x204838@ 1536x 1024	6.3M/IMX178 (C,RS)1/1.8" (7.37x4.92)
Venuslab-ISP6.3KP-B	1x1 2x2	2.4x2.4	425mv with 1/30s 0.15mv with 1/30s	0.02ms~15s	59@3072 x204859@ 1536x 1024	6.3M/IMX178 (C,RS)1/1.8" (7.37x4.92)
Venuslab-ISP5.1KP-A	1x1 2x2	2.74x2.74	1337mv with 1/30s 0.15mv with 1/30s	0.03ms~15s	63@2448x2048208.4@ 1224x1024	5.1M/IMX547 (C,GS)1/1.8" (6.71x5.61)
Venuslab-ISP5.0KP-A	1x1 1x1	3.45x3.45	1146mv with 1/30s 0.15mv with 1/30s	0.1ms~15s	35@2448x204850@ 1224x1024	5.0M/IMX264 (C, GS)2/3" (8.45x7.07)
Venuslab-ISP3.1KP-A	1x1 1x1	3.45x3.45	1146mv with 1/30s 0.15mv with 1/30s	0.1ms~15s	53@2048x153685@ 1024x768	3.1M/IMX265 (C, GS)1/1.8" (7.07x5.30)
Venuslab-ISP02KP-A	1x1	3.75x3.75	2350mv with 1/30s 0.15mv with 1/30s	0.1ms~15s	125@1920x1080	2M/IMX385(C) 1/2"(7.2x4.05)
Venuslab-ISP1.5KP-A	1x1 2x2	3.45x3.45	1146mv with 1/30s 0.15mv with 1/30s	0.1ms~15s	164@1440x1080320@ 720x540	1.5M/IMX273 (C, GS)1/2.9" (4.968x3.726)
Venuslab-ISP20KP-D	1x1 2x2 3x3	2.4 x2.4	462mv with 1/30s 0.21mv with 1/30s	0.1ms~15s	15@5440x364850@ 2736x182460@ 1824x1216	20M/IMX283 (C,RS) 1"(13.06x8.76)
Venuslab-ISP3.1KP-B	1x1 1x1	2.5x2.5	600mv with 1/30s 0.15mv with 1/30s	0.1ms~15s	50@2048x153650@ 1920x1080	3.1M/IMX123 (C)1/2.8" (5.12x3.84)
Venuslab-ISP2.1KP-A	1x1	5.8x5.8	8935mv with 1/30s 0.6mv with 1/30s	14us~15s	96@1920x1080	2.1M/IMX482 (C)1/1.2" (11.14x6.26)

 Get in touch with our team to explore configurations, request a quote, or learn more about customized solutions tailored to your needs.

Let us help you move science forward—faster and smarter.

[Get a Quote](#)



Get Expert Advice  
+658099 5547 ( WhatsApp )



Visit Us  
[www.venuslabtech.com](http://www.venuslabtech.com)