

CCD Cameras

Venuslab ExView MTR3 Camera

High-end imaging for scientific research & precision testing

- Dual-stage semiconductor deep refrigeration technology
- High-sensitivity and low-noise architecture
- High-speed interface and full-scenario compatibility
- Industrial-grade durable design

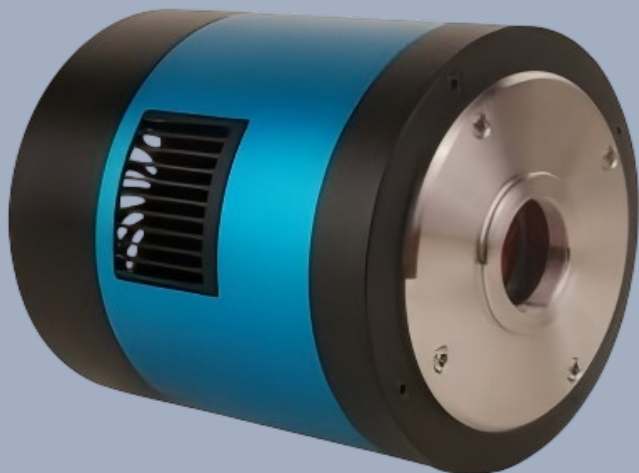

One Platform Many Possibilities

Contact Us sales@venuslabtech.com

Get a Quote



Get Expert Advice
+658099 5547 (WhatsApp)



Visit Us
www.venuslabtech.com

Overview

Introduction to Venuslab ExView MTR3 Camera :

The Venuslab ExView MTR3 Camera is a scientific-grade device specifically designed for low-light high-fidelity imaging scenarios. It is equipped with Sony ExView HAD or HAD CCD sensors, with resolutions ranging from 1.4 million to 6 million pixels. Adopting a two-stage thermoelectric cooling system, it can lower the sensor temperature to 30-50 °C below the ambient temperature. Combined with an anti-fog structure and an integrated heat pipe for efficient heat dissipation design, it can significantly reduce dark current noise and avoid the impact of low-temperature fogging. The camera is equipped with a standard C interface to adapt to mainstream optical equipment, achieves high-speed data transmission of 5Gbps through a USB3.0 interface, and supports long-time exposure from 0.06ms to 1 hour as well as software/external trigger modes. It is equipped with the Ultra-Fine™ color processing engine and 16-bit signal acquisition, which can accurately restore image details and colors. It provides multi-platform SDKs for Windows/Linux/OSX and ToupView image processing software, supporting rich functions such as image measurement and filtering enhancement. It is widely applicable to scientific research and precision detection scenarios such as fluorescence microscopy imaging, cell observation, semiconductor defect detection, and astrophotography, and can operate stably in a wide temperature environment of -10 °C ~50 °C.

Features:

- Standard C interface, equipped with a Sony ExView HAD CCD II sensor with 1.4 million - 12 million pixels;
- Two - stage thermoelectric cooling + controllable fan, the sensor temperature can drop to 40 °C below the ambient temperature, and stabilize to the set temperature within 5 minutes;
- Intelligent structure temperature control to prevent fogging, equipped with IR - CUT/AR coating window, supporting 1 - hour long exposure;
- USB3.0 (5Gbps) high - speed data transmission, Ultra - Fine color engine to restore accurate colors;
- Providing multi - system SDKs for Windows/Linux/Mac and various control APIs such as C/C++, C#.

Dimension:

Schematic diagram of the external dimensions of the Venuslab ExView MTR3 Camera. The camera housing is made of hard aluminum alloy through CNC precision machining. A high-quality IR-CUT or double-sided AR protective glass is installed at the front end of the camera sensor, which mainly functions to filter out infrared light waves in imaging and protect the camera sensor at the same time. Venuslab's TE-cooled cameras have good sealing performance, and after the camera's cooling fan is vibration-damped, there will be no image blurring caused by fan vibration.

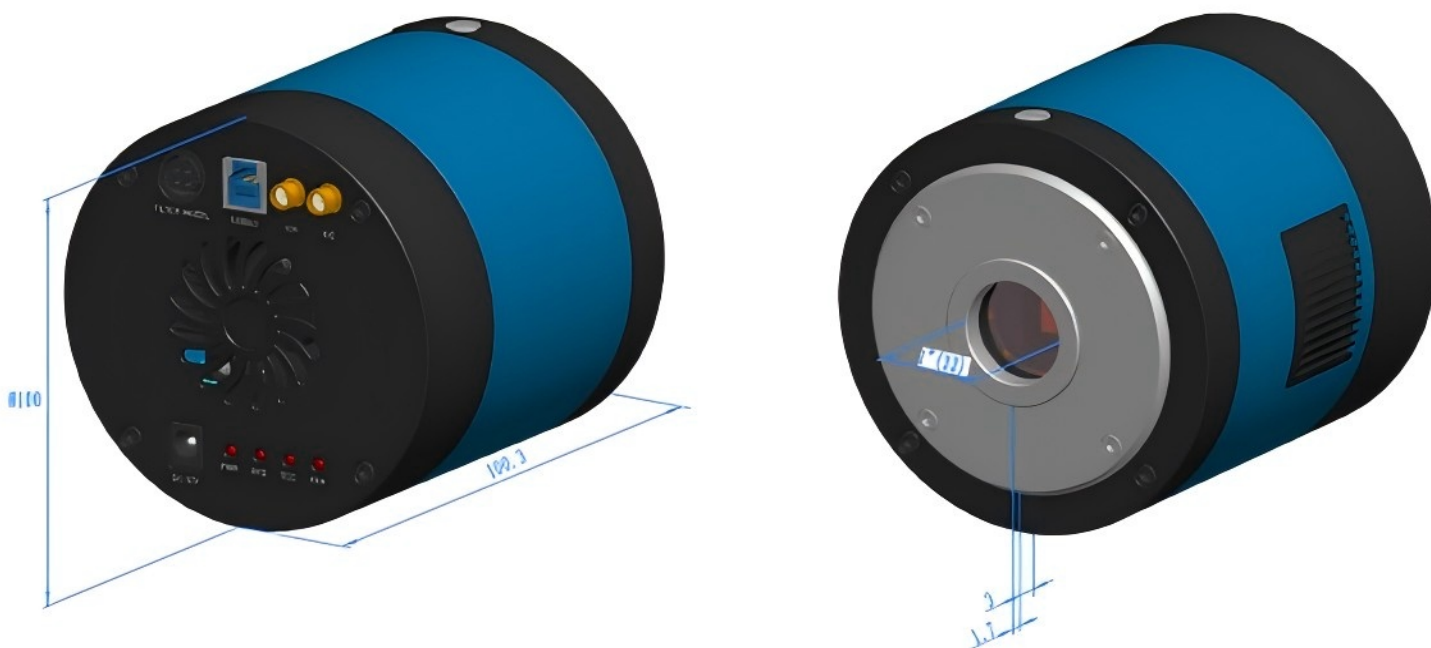

Specifications

Venuslab ExView MTR3 Camera Common Parameter Specification Table

Other Specification	
Spectral Range	380-650nm (with IR-cut Filter)
White Balance	ROI White Balance/ Manual Temp Tint Adjustment/NA for Monochromatic Sensor
Color Technique	Ultra-Fine Color Engine/NA for Monochromatic Sensor
Capture/Control SDK	Windows/Linux/macOS/Android Multiple Platform SDK(Native C/C++, C#/VB.NET, Python, Java, DirectShow, Twain, etc)
ADC	8 Bit / 14 Bit
Recording System	Still Picture and Movie
Cooling System*	Two-stage TE-cooling System -45 °C below Camera Body Temperature
Operating Environment	
Operating Temperature (in Centidegree)	-10 - 50
Storage Temperature (in Centidegree)	-20 - 60
Operating Humidity	30 - 80% RH
Storage Humidity	10 - 60% RH
Power Supply	DC 5V over PC USB Port; External Power Adapter for Cooling System, DC12V, 3A
Software Environment	
Operating System	Microsoft® Windows® XP / Vista / 7 / 8 /10 /11 (32 & 64 bit) OSx(Mac OS X)Linux
PC Requirements	CPU: Equal to Intel Core2 2.8GHz or Higher
	Memory: 2GB or More
	USB Port: USB3.0 High - speed Port
	Display: 17" or Larger
	CD - ROM

Packing List

Packing Information for Venuslab ExView MTR3 Camera



Standard Package			
A	Carton L:50cm W:30cm H:30cm (20pcs, 12~17Kg/ carton), not shown in the photo		
B	3-A safety equipment case: L:28cm W:23cm H:15cm (1pcs, 2.8Kg/ box); Carton size:L:28.2cm W:25.2cm H:16.7cm		
C	One MTR3CCD series camera(C-mount)		
D	Power adapter: input: AC 100~240V 50Hz/60Hz, output: DC12 V 3A		
E	High-speed USB3.0 A male to B male gold-plated connectors cable /2.0m		
F	CD (Driver & utilities software, Ø12cm)		
Optional Accessory			
G	Adjustable lens adapter	C-mount to Dia.23.2mm eyepiece tube(Please choose 1 of them for your microscope)	108001/AMA037108002/ AMA050108003/ AMA075108004/AMA100
		C-Mount to Dia.31.75mm eyepiece tube(Please choose 1 of them for your telescope)	108008/ATA037108009/ ATA050108010/ATA075108011/ ATA100
H	Fixed lens adapter	C-mount to Dia.23.2mm eyepiece tube(Please choose 1 of them for your microscope)	108005/FMA037108006/ FMA050108007/FMA075108008 /FMA100
		C-mount to Dia.31.75mm eyepiece tube(Please choose 1 of them for your telescope)	108011/FTA037108012/ FTA050108013/FTA075108014/ FTA100
Note: For G and H optional items, please specify your camera type(C-mount, microscope camera or telescope camera), ToupTek engineer will help you to determine the right microscope or telescope camera adapter for your application;			
I	108015(Dia.23.2mm to 30.0mm ring)/Adapter rings for 30mm eyepiece tube		
J	108016(Dia.23.2mm to 30.5mm ring)/ Adapter rings for 30.5mm eyepiece tube		
K	External trigger control line		
L	Calibration kit	106011/TS-M1(X=0.01mm/100Div.);106012/TS-M2(X,Y=0.01mm/100Div.);106013/TS-M7(X=0.01mm/100Div., 0.10mm/100Div.)	

Service & Support

We are dedicated to delivering exceptional optoelectronic solutions to every client. From precision manufacturing and secure delivery to full-lifecycle technical support, we are here to ensure a seamless and reliable experience at every step.

1. Warranty Policy

Quality First, Worry-Free Operation

Warranty Period: We offer a **two-year** warranty service for all of our core optoelectronic products, effective from the date of shipment.

Coverage: We provide free repair or replacement services for malfunctions caused by material defects or workmanship errors under normal operating conditions.

Rapid Response: Upon receiving a warranty claim, we guarantee to initiate the assessment process within **24 hours** to minimize your equipment downtime.

2. Technical Support

Expert Team, Full-Process Guidance

Technical Consultation: Our team of senior optical engineers provides **24/7 online support** to assist with installation, commissioning, optical path alignment, and parameter optimization.

Scheduled Maintenance: We offer full-lifecycle maintenance recommendations, including firmware upgrades, optical component cleaning guidelines, and precision calibration services.

Training Services: We provide customized remote or on-site operational and safety training to ensure your team can operate the equipment efficiently and safely.

3. Logistics & Delivery

Precision Packaging, Global Reach

Professional Packaging: Given the fragile nature of optical instruments, we utilize industrial-grade shockproof, anti-static, and moisture-proof vacuum packaging to ensure zero damage during transit.

Logistics Partners: We partner with top-tier global logistics providers (**DHL / FedEx / UPS / SF Express**) to offer reliable shipping with real-time tracking.

Shipping Insurance: All shipments are fully insured to eliminate logistics risks.

4. Compliance & Certification

Strict Standards, Total Compliance

Quality Certification: Our manufacturing process is **ISO 9001 certified**, and our products comply with international standards such as **CE** and **RoHS**.

Export Compliance: "Committed to environmental responsibility, all our products comply with **RoHS 2.0** and **REACH** standards, ensuring safety and global compliance."

Explore Series

MP112000A	420mv with 1/30s 15.2mv with 1/10s	12M/ICX834AQG(C) 1" (13.15x8.77)	0.06ms - 1h	1x1 2x2	3.6@4248x2836 6.6@1224x1416	3.1x3.1
MM112000A	420mv with 1/30s 15.2mv with 1/10s	12M/ICX834ALM(G) 1" (13.15x8.77)	0.06ms - 1h	1x1 2x2	3.6@4248x2836 6.6@1224x1416	3.1x3.1
MP109000A	580mv with 1/30s 8.2mv with 1/10s	9M/ICX814AQG(C) 1" (12.47x9.98)	0.06ms - 1h	1x1 2x2	4.4@3388x2712 4.6@1694x1356	3.69x3.69
MM109000A	660mv with 1/30s 8.2mv with 1/10s	9M/ICX814ALM(G) 1" (12.47x9.98)	0.06ms - 1h	1x1 2x2	4.4@3388x2712 4.6@1694x1356	3.69x3.69
MP106000A	880mv with 1/10s 8.8mv with 1/10s	6M/ICX694AQG(C) 1" (12.48x9.99)	0.06ms - 1h	1x1 2x2	7.5@2748x2200 12.6@ 1374x1152	4.54x4.54
MM106000A	1000mv with 1/30s 8.8mv with 1/10s	6M/ICX694ALM(G) 1" (12.48x9.99)	0.06ms - 1h	1x1 2x2	7.5@2748x2200 12.6@ 1374x1152	4.54x4.54
MP102800A	800mv with 1/30s 9mv with 1/30s	2.8M/ICX674AQG(C) 2/3" (8.81x6.63)	0.05ms - 1h	1x1 2x2	15.6@ 1936x1412 17@968x702	4.54x4.54
MM102800A	950mv with 1/30s 9mv with 1/30s	2.8M/ICX674ALM(G) 2/3" (8.81x6.63)	0.05ms - 1h	1x1 2x2	15.6@ 1936x1412 17@968x702	4.54x4.54
MP101400A	1240mv with 1/30s 10mv with 1/30s	1.4M/ICX825AQG(C) 2/3" (8.8x6.6)	0.07ms - 1h	1x1	15@1360x1024	6.45x6.45
MM101400A	1300mv with 1/30s 10mv with 1/30s	1.4M/ICX825ALM(G) 2/3" (8.8x6.6)	0.07ms - 1h	1x1	15@1360x1024	6.45x6.45
MP101400B	2000mv with 1/30s 10mv with 1/30s	1.4M/ICX825AQM(C) 2/3" (8.8x6.6)	0.07ms - 1h	1x1	8.8@1376x1040	6.45x6.45
MM101400B	2000mv with 1/30s 10mv with 1/30s	1.4M/ICX825ALM(G) 2/3" (8.8x6.6)	0.07ms - 1h	1x1	8.8@1376x1040	6.45x6.45

 Get in touch with our team to explore configurations, request a quote, or learn more about customized solutions tailored to your needs.

Let us help you move science forward—faster and smarter.

[Get a Quote](#)



Get Expert Advice
+658099 5547 (WhatsApp)



Visit Us
www.venuslabtech.com