

# Confocal/Raman Microscopy

## In-Situ Microelectrochemical Raman Spectrometer

Portable Research-Grade In-situ Spectral Analysis All-in-One System

- Ultimate "Three-in-One" Integrated Design
- Superior In-situ Characterization & Detection Capabilities
- Flexible Wavelength Expansion & Configuration
- Intelligent Software System



One Platform Many Possibilities

Contact Us [sales@venuslabtech.com](mailto:sales@venuslabtech.com)

Get a Quote



Get Expert Advice  
+658099 5547 ( WhatsApp )



Visit Us  
[www.venuslabtech.com](http://www.venuslabtech.com)

## Overview

### "Explorer of the Microscopic World" – In-situ Microchemical Raman Spectrometer

The In-situ Microelectrochemical Raman Spectrometer is a state-of-the-art analytical instrument designed for on-site chemical composition analysis of samples. It utilizes Raman spectroscopy to non-destructively identify and quantify the chemical bonds and molecular structures on the sample surface. With high spatial resolution and sensitivity, it is suitable for various fields such as materials science, biomedicine, environmental science, and forensics. Its compact design and user-friendly interface make operation straightforward, and data acquisition and analysis are fast and accurate. The In-situ Microchemical Raman Spectrometer is an ideal tool for researchers and industrial analysts conducting microscopic structural studies and chemical composition analysis.

### Characteristics of In-situ Microchemical Raman Spectrometer

- In-situ chemical Raman spectroscopy analysis, non-destructive testing.
- High spatial resolution, suitable for materials science, biomedicine, environmental monitoring, etc.
- Flexible and portable, with scientific research-level precision, supporting multi-wavelength measurement.
- Integrated electrochemical testing and Raman spectroscopy analysis for real-time monitoring of chemical changes.
- Equipped with a high-stability laser and a constant-temperature refrigerated detector to ensure high-quality spectral collection.
- Comprehensive software functions, including automatic exposure, noise reduction algorithm, peak identification and area calculation.
- Customizable design to meet different scientific research needs.

### Dimension drawing

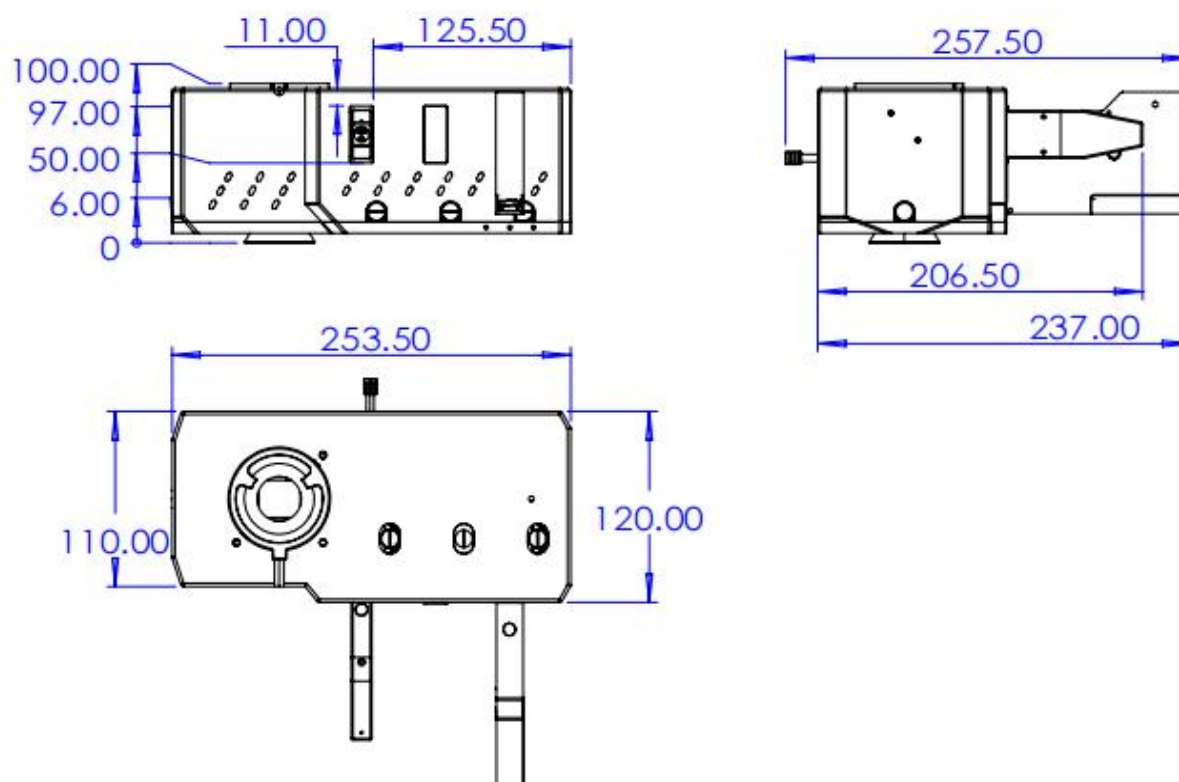

## Specifications

### Parameter table

Parameter Name	Specification
Excitation Wavelength	785±0.5 nm (Linewidth 0.08 nm), supports fast multi-wavelength switching (532/633/1064 nm, etc.)
Spectral Coverage	200-3000 cm <sup>-1</sup>
Spectral Resolution	~8 cm <sup>-1</sup> @25µm Slit
Raman Shift Accuracy/Repeatability	≤1 cm <sup>-1</sup> (Accuracy); ≤1 cm <sup>-1</sup> (Repeatability)
Potential Measurement Range	±5 V
Current Detection Sensitivity	1 pA
Signal Enhancement Multiple	Million-fold level (Shell-Isolated Nanoparticle-Enhanced Raman Scattering)
Low Concentration Detection Limit	Capable of detecting characteristic peaks of 0.5% ethanol aqueous solution
In-situ Cell Performance	Acid/alkali resistant (Teflon structure), compatible with three-electrode system
Laser Power	0-500 mW adjustable (Stability 3% P-P @2hrs)
Micro-area Positioning Spot	1 µm

## Typical spectrum

### (1) Silicon wafer

Detection conditions: 50X lens, power 40 mW, time 2 min

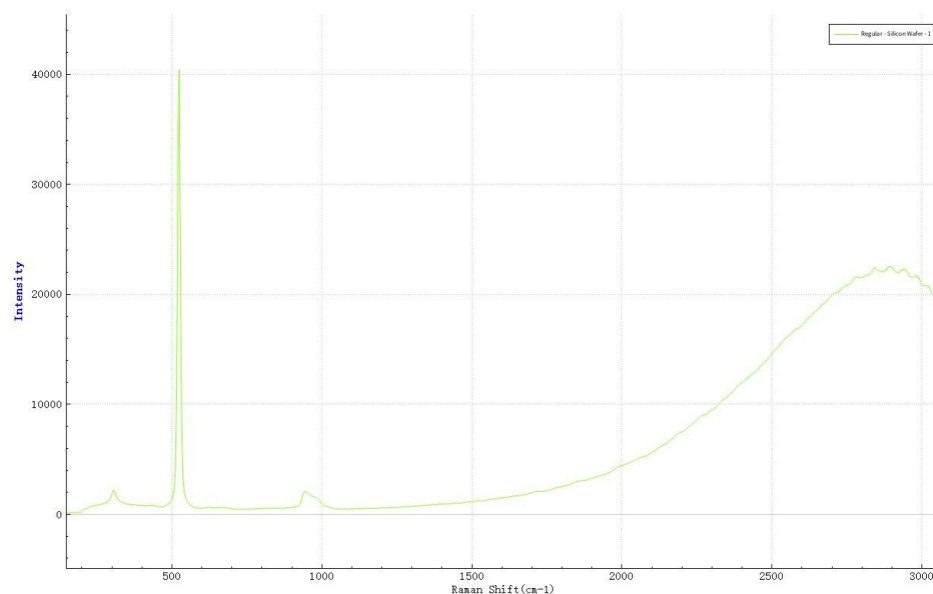

(2)0.5% ethanol

Test conditions: 50X lens, 100% power, 1s

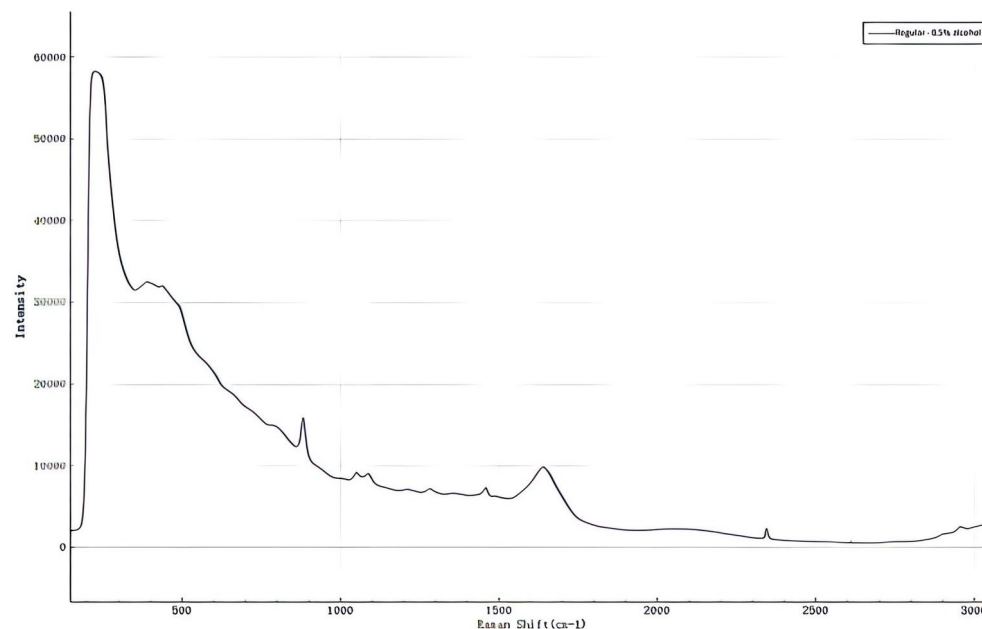

## Applications

Using the in-situ electrochemical SERS borrowing strategy, the oxygen reduction reaction (ORR) processes of Au@Pt and Au@PtNi series nanoparticles were studied, and direct Raman spectral evidence of the intermediate OOH was captured (verified by isotope experiments). The results show that Ni doping can enhance the binding force between OOH and the Pt surface, optimize electron transfer, and the adsorption energy of \*OOH on PtNi is lower, which can significantly improve ORR activity; adjusting the content of transition metals (TM) in the alloy can further optimize the activity. This strategy provides an effective means for in-situ observation of catalytic processes.

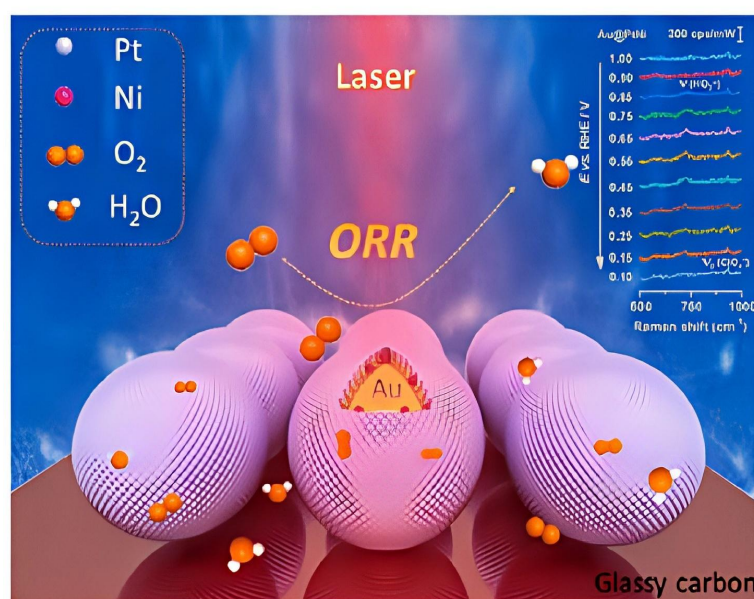

J. Am. Chem. Soc. 2021, 143, 3, 1318–1322

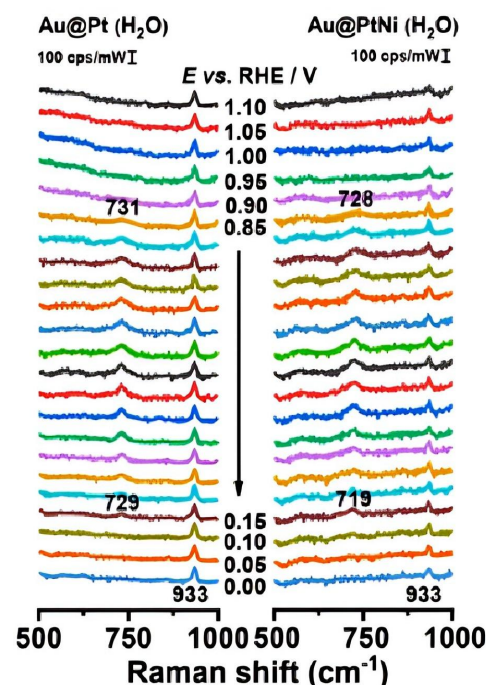

Using in-situ electrochemical shell-isolated nanoparticle-enhanced Raman spectroscopy (SHINERS) combined with theoretical calculations, the electrooxidation behavior of CO on Pt (hkl) surfaces in acidic solutions was studied. The results show that CO on Pt (111) and Pt (100) surfaces has both top-site and bridge-site adsorption, while only top-site adsorption occurs on Pt (110). Verified by isotope substitution experiments and density functional theory, the formation and adsorption of OH and COOH\* are crucial for CO electrooxidation and are related to the pre-oxidation peak. This study systematically reveals the adsorption and electrooxidation mechanisms of CO on Pt single-crystal electrodes, providing a new perspective for the design of anti-poisoning and high-efficiency catalysts.

## In-situ electrochemical Raman results

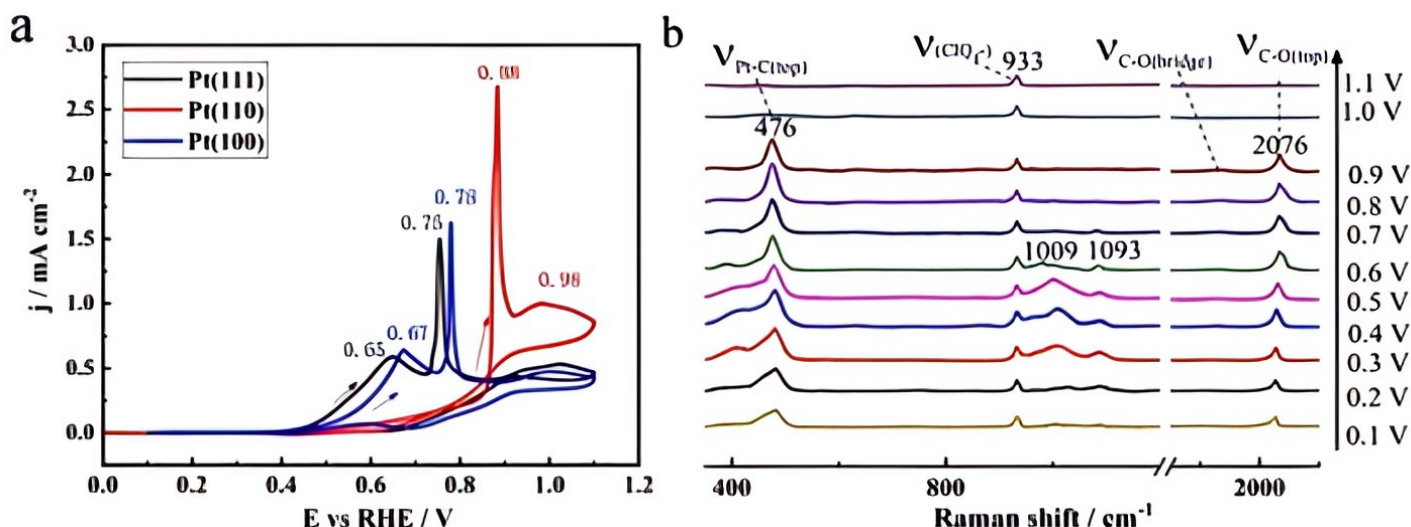

## Service & Support

We are dedicated to delivering exceptional optoelectronic solutions to every client. From precision manufacturing and secure delivery to full-lifecycle technical support, we are here to ensure a seamless and reliable experience at every step.

### 1. Warranty Policy

#### Quality First, Worry-Free Operation

**Warranty Period:** We offer a **two-year** warranty service for all of our core optoelectronic products, effective from the date of shipment.

**Coverage:** We provide free repair or replacement services for malfunctions caused by material defects or workmanship errors under normal operating conditions.

**Rapid Response:** Upon receiving a warranty claim, we guarantee to initiate the assessment process within **24 hours** to minimize your equipment downtime.

### 2. Technical Support

#### Expert Team, Full-Process Guidance

**Technical Consultation:** Our team of senior optical engineers provides **24/7 online support** to assist with installation, commissioning, optical path alignment, and parameter optimization.

**Scheduled Maintenance:** We offer full-lifecycle maintenance recommendations, including firmware upgrades, optical component cleaning guidelines, and precision calibration services.

**Training Services:** We provide customized remote or on-site operational and safety training to ensure your team can operate the equipment efficiently and safely.

### 3. Logistics & Delivery

#### Precision Packaging, Global Reach

**Professional Packaging:** Given the fragile nature of optical instruments, we utilize industrial-grade shockproof, anti-static, and moisture-proof vacuum packaging to ensure zero damage during transit.

**Logistics Partners:** We partner with top-tier global logistics providers (**DHL / FedEx / UPS / SF Express**) to offer reliable shipping with real-time tracking.

**Shipping Insurance:** All shipments are fully insured to eliminate logistics risks.

### 4. Compliance & Certification

#### Strict Standards, Total Compliance

**Quality Certification:** Our manufacturing process is **ISO 9001 certified**, and our products comply with international standards such as **CE and RoHS**.

**Export Compliance:** "Committed to environmental responsibility, all our products comply with **RoHS 2.0 and REACH standards**, ensuring safety and global compliance."

## Explore Series

Model	Size	Excitation Wavelength	Spectral Coverage	Weight
VL-RM-EC-785	325x220x99 mm	785 ± 0.5 nm, Linewidth ≤ 0.08nm	200-3000 cm <sup>-1</sup>	4.4 kg

Get in touch with our team to explore configurations, request a quote, or learn more about customized solutions tailored to your needs.

Let us help you move science forward—faster and smarter.

Get a Quote



Get Expert Advice  
+658099 5547 (WhatsApp)



Visit Us  
www.venuslabtech.com