

Optical Prisms

Penta Prism

A precision 90° beam steering element defined by its optical invariance

- Constant 90° Deviation
- No Image Inversion or Reversion
- Dual-Surface Metallic Coatings
- Superior Angular Accuracy

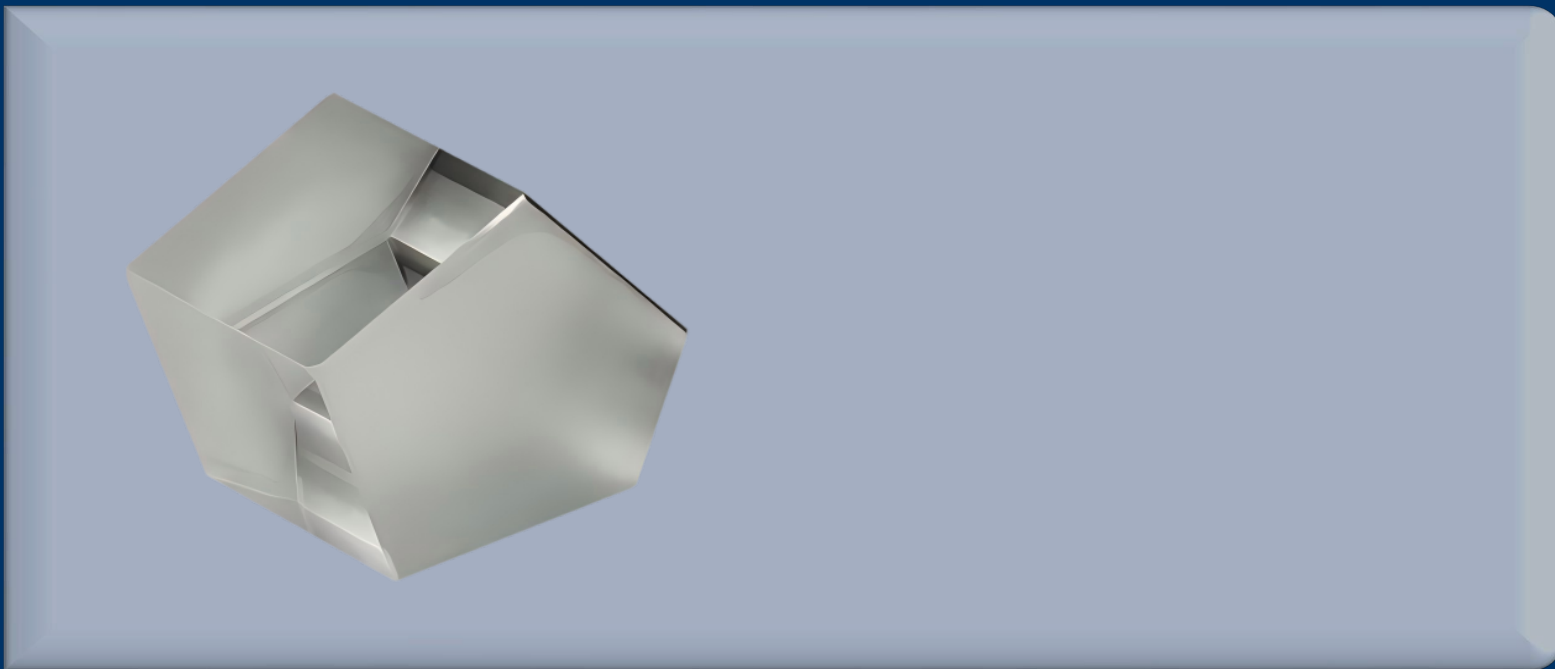

One Platform Many Possibilities

Contact Us sales@venuslabtech.com

Get a Quote



Get Expert Advice
+658099 5547 (WhatsApp)



Visit Us
www.venuslabtech.com

Overview

Constant 90° Deviation: Precision Steering Unaffected by Alignment Errors

The Penta Prism is a highly precise steering component characterized by its ability to deviate an incident beam by exactly 90°, regardless of the prism's own orientation or minor tilt. This "angular invariance" makes it the ultimate reference component for long-range surveying, optical leveling, and alignment systems where mechanical stability may be a concern.

Unlike a standard right-angle prism, the Penta Prism does not invert or revert the image, maintaining the original orientation of the transmitted scene. Because the internal reflections do not rely on Total Internal Reflection (TIR), the two reflecting surfaces are vacuum-deposited with high-performance metallic coatings (Aluminum or Silver) and protected by black paint. VenusLab offers Penta Prisms with angular tolerances as low as **2 arc sec**, ensuring superior pointing accuracy for your most demanding applications.

Structural Diagram:

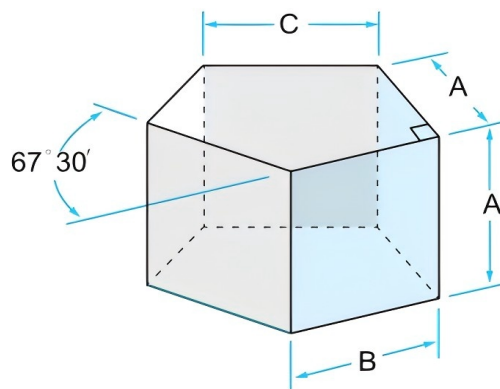

Qualification

Technical Specifications

Parameter	Specification
Material	K9 Grade A Optical Glass (N-BK7 Equivalent)
90° Deviation Tolerance	± 30 arc sec (Standard) / ± 2 arc sec
Surface Flatness	/4 @ 632.8 nm (Standard) / /10 (High Precision)
Surface Quality	40-20 Scratch-Dig
Clear Aperture	> 90% of Surface Dimensions
Reflective Coating	Aluminum or Silver + Black Paint (Protective)
AR Coating (Entry/Exit)	Uncoated / AR Coating (Optional)
Dimension Tolerance	± 0.1 mm

Selection Chart

Ordering Information

Item No.	Size (S) (mm)	Side Length (L) (mm)	Material
VLPP10	10.0	11.0	K9 (N-BK7)
VLPP20	20.0	22.0	K9 (N-BK7)
VLPP25	25.4 (1")	28.0	K9 (N-BK7)

Service & Support

We are dedicated to delivering exceptional optoelectronic solutions to every client. From precision manufacturing and secure delivery to full-lifecycle technical support, we are here to ensure a seamless and reliable experience at every step.

1. Warranty Policy

Quality First, Worry-Free Operation

Warranty Period: We offer a **two-year** warranty service for all of our core optoelectronic products, effective from the date of shipment.

Coverage: We provide free repair or replacement services for malfunctions caused by material defects or workmanship errors under normal operating conditions.

Rapid Response: Upon receiving a warranty claim, we guarantee to initiate the assessment process within **24 hours** to minimize your equipment downtime.

2. Technical Support

Expert Team, Full-Process Guidance

Technical Consultation: Our team of senior optical engineers provides **24/7 online support** to assist with installation, commissioning, optical path alignment, and parameter optimization.

Scheduled Maintenance: We offer full-lifecycle maintenance recommendations, including firmware upgrades, optical component cleaning guidelines, and precision calibration services.

Training Services: We provide customized remote or on-site operational and safety training to ensure your team can operate the equipment efficiently and safely.

3. Logistics & Delivery

Precision Packaging, Global Reach

Professional Packaging: Given the fragile nature of optical instruments, we utilize industrial-grade shockproof, anti-static, and moisture-proof vacuum packaging to ensure zero damage during transit.

Logistics Partners: We partner with top-tier global logistics providers (**DHL / FedEx / UPS / SF Express**) to offer reliable shipping with real-time tracking.

Shipping Insurance: All shipments are fully insured to eliminate logistics risks.

4. Compliance & Certification

Strict Standards, Total Compliance

Quality Certification: Our manufacturing process is **ISO 9001 certified**, and our products comply with international standards such as **CE** and **RoHS**.

Export Compliance: "Committed to environmental responsibility, all our products comply with **RoHS 2.0** and **REACH** standards, ensuring safety and global compliance."

Explore Series

Model	Side Length (L) (mm)	Material	Size (S) (mm)
VLPP10	11.0	K9 (N-BK7)	10.0
VLPP20	22.0	K9 (N-BK7)	20.0
VLPP25	28.0	K9 (N-BK7)	25.4(1")

 Get in touch with our team to explore configurations, request a quote, or learn more about customized solutions tailored to your needs.

Let us help you move science forward—faster and smarter.

[Get a Quote](#)



Get Expert Advice
+658099 5547 (WhatsApp)



Visit Us
www.venuslabtech.com