

# Photodiodes

## UV-enhanced Silicon PIN Photodiode (DIP Package)

Optoelectronic conversion devices with DIP dual in-line package

- High-sensitivity detection in the ultraviolet band
- Engineering adaptability of DIP packaging
- Wide temperature range stability and low noise
- Plug-and-play compatibility for multiple scenarios

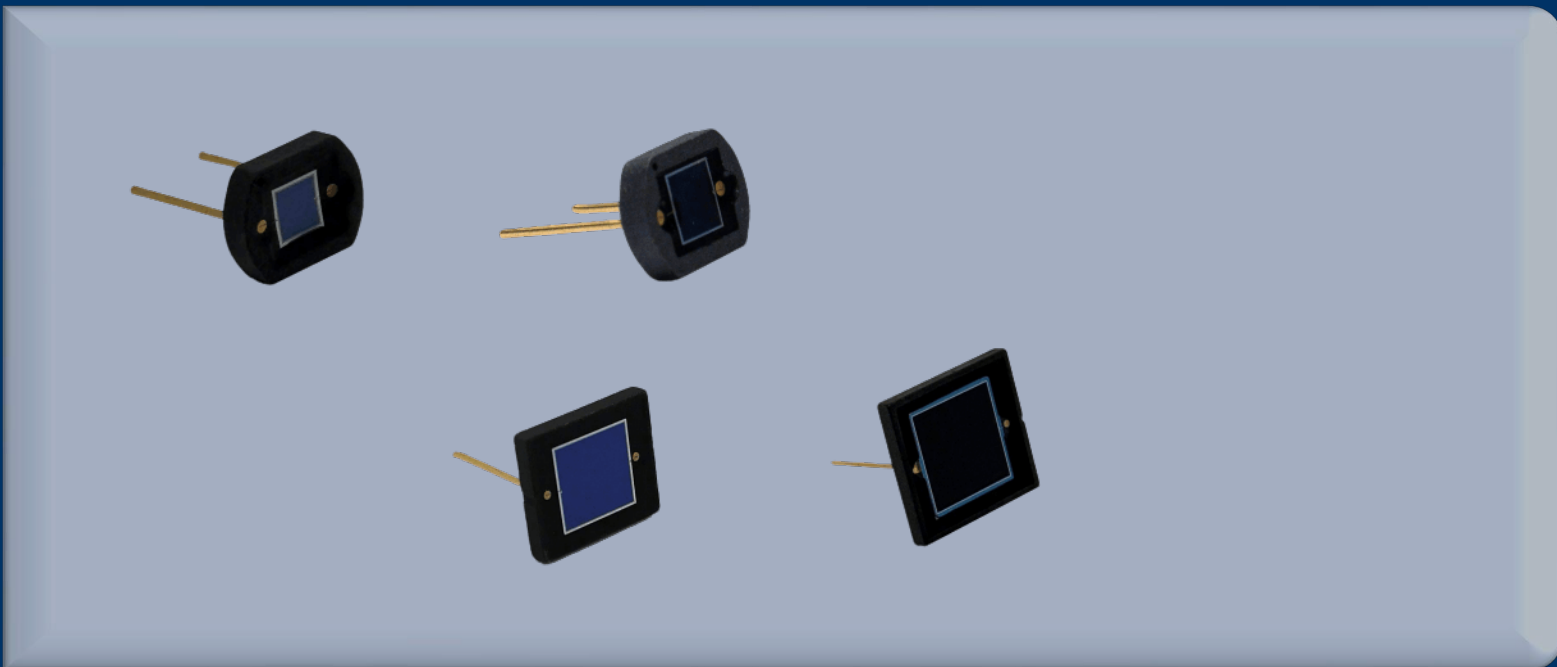

One Platform Many Possibilities

Contact Us [sales@venuslabtech.com](mailto:sales@venuslabtech.com)

Get a Quote



Get Expert Advice  
+658099 5547 ( WhatsApp )



Visit Us  
[www.venuslabtech.com](http://www.venuslabtech.com)

## Overview

### Introduction:

This ultraviolet-enhanced silicon PIN photodiode has a spectral response range of 250~1060nm, featuring low dark current, low junction capacitance, and optimized ultraviolet response. It adopts a DIP package and is suitable for optical power detection and optical analysis equipment. It efficiently captures ultraviolet light signals, while being compatible with the inherent near-infrared band (700~1100nm) response capability of silicon PIN diodes, and is suitable for through-hole circuit installation scenarios.

### Features:

- Composite coating with UV aging resistance
- Deep ultraviolet passivation to suppress leakage current
- DIP housing with vibration resistance and reliability
- Minimal cross-section response fluctuation

### Dimension:

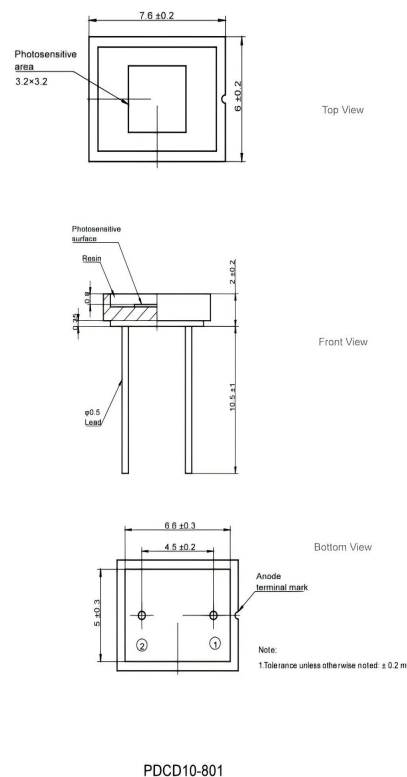
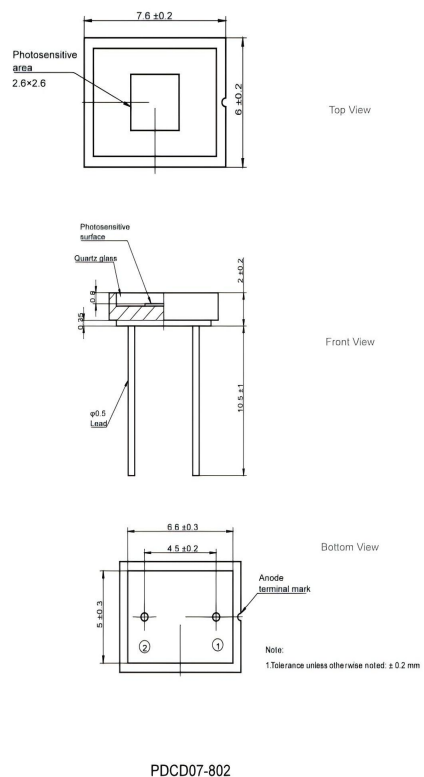
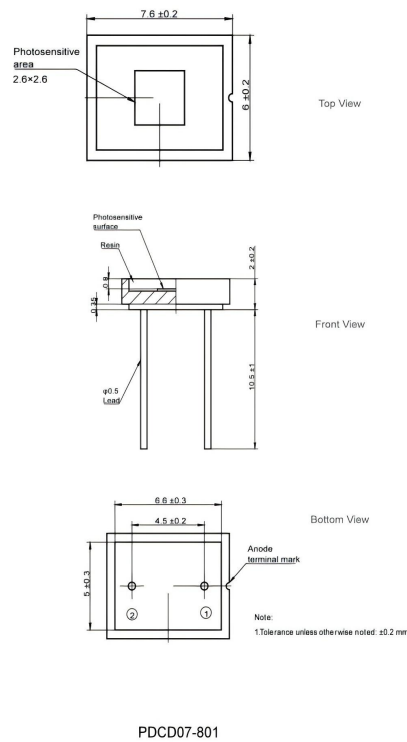
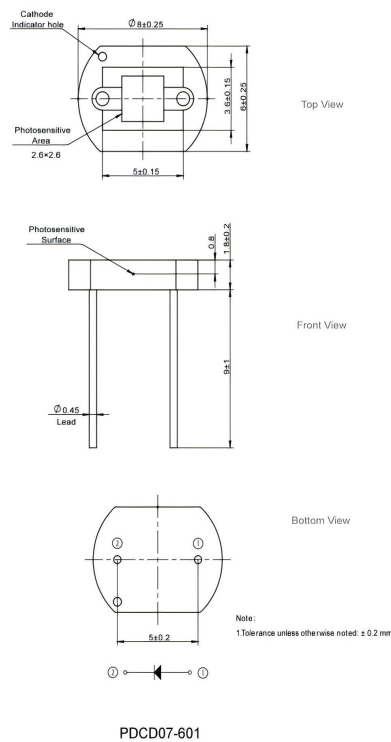

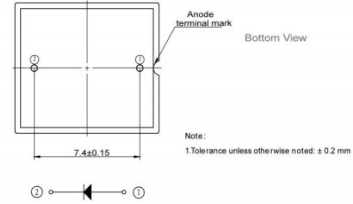
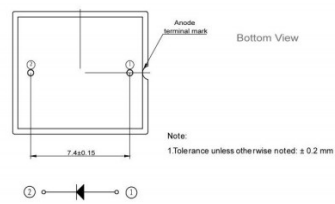
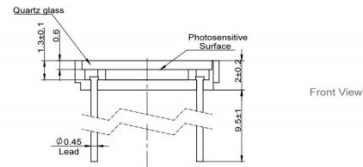
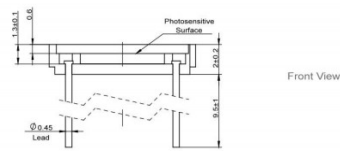
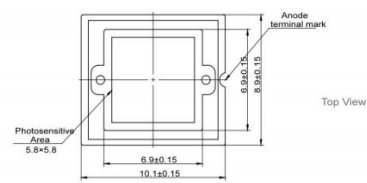
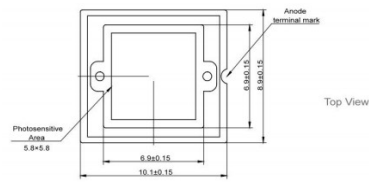

PDCD34-701

PDCD34-703

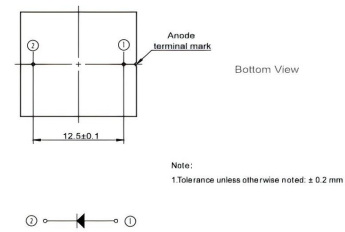
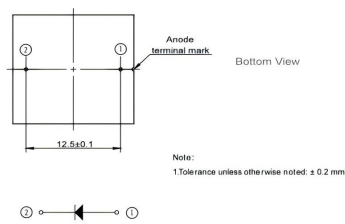
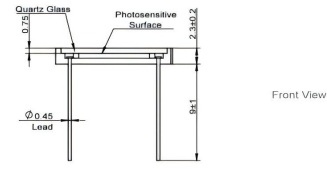
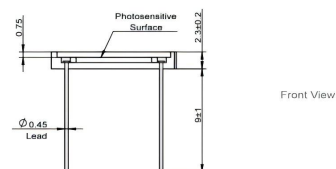
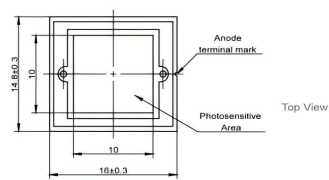
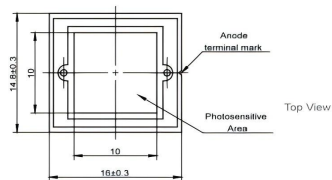

PDCD100-301

PDCD100-302

## Specifications

### Common Parameter Specification Table

Core Parameter Name	Parameter Value
Package Type	DIP (Dual In-line Package)
Storage Temperature ( )	-20 to +80 (No Condensation)
Operating Temperature ( )	-20 to +80 (No Condensation)
Soldering Temperature ( )	(<5s) 260
Maximum Reverse Voltage (V)	20
HBM Mode ESD Protection (V)	1000
Peak Response Wavelength (nm)	800

## Applications

### Spectral response

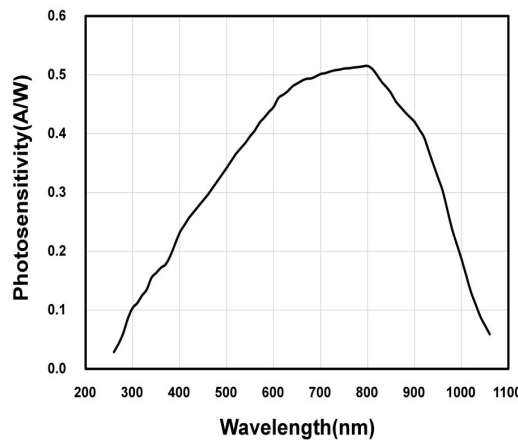
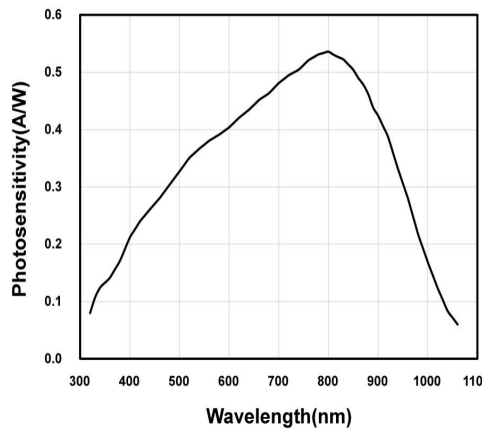

### Dark current vs. reverse voltage

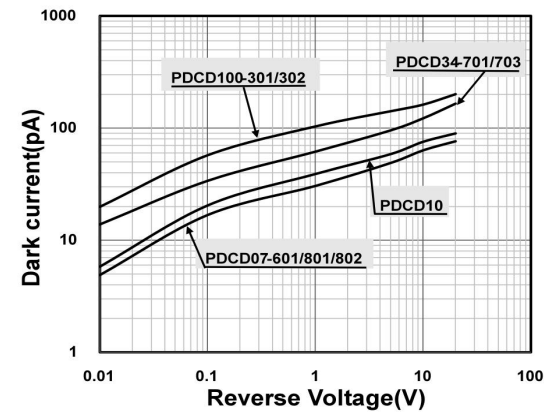

Corresponding product - Resin window

Corresponding product - Quartz window

### Junction capacitance vs. reverse voltage

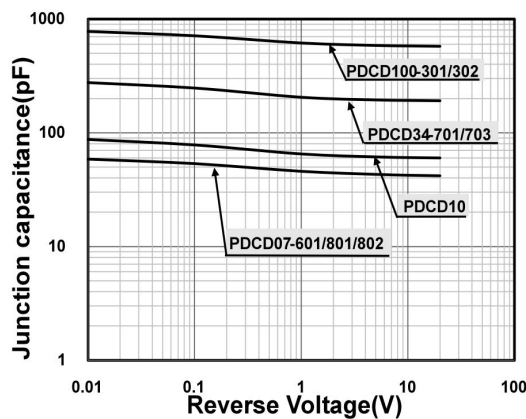

### Photosensitivity temperature characteristics

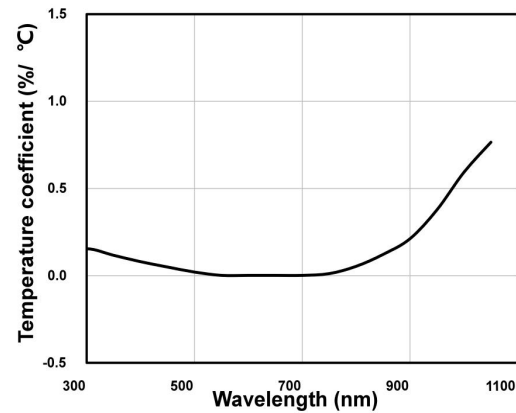

## Explore Series

Model	Dark Current (Max, pA)	Window Material	Photosensitive Area Size (mm)	Junction Capacitance (Max, pF)	Equivalent Noise Power (W/Hz <sup>1/2</sup> )	Spectral Response Range (nm)
PDCD07-601	30	Resin	2.6×2.6	80	$5.3 \times 10^{-15}$	320~1060
PDCD07-801	50	Resin	2.6×2.6	90	$5.7 \times 10^{-15}$	320~1060
PDCD07-802	50	Quartz	2.6×2.6	90	$6.7 \times 10^{-15}$	250~1060
PDCD10-801	90	Resin	3.2×3.2	120	$9.2 \times 10^{-15}$	320~1060
PDCD34-701	300	Resin	5.8×5.8	400	$9.9 \times 10^{-15}$	320~1060
PDCD34-703	300	Quartz	5.8×5.8	400	$9.9 \times 10^{-15}$	250~1060
PDCD100-301	800	Resin	10×10	1000	$1.2 \times 10^{-14}$	320~1060
PDCD100-302	800	Quartz	10×10	1000	$1.3 \times 10^{-14}$	250~1060

Get in touch with our team to explore configurations, request a quote, or learn more about customized solutions tailored to your needs.

Let us help you move science forward—faster and smarter.

Get a Quote



Get Expert Advice  
+658099 5547 ( WhatsApp )



Visit Us  
www.venuslabtech.com