

Scientific Cameras

VenusLab Scientific sCMOS Camera

High-end imaging equipment for cutting-edge research

- Ultra-weak light detection capability
- High-speed dynamic imaging
- Stable low-noise output
- Flexible integration and adaptation



One Platform Many Possibilities

Contact Us sales@venuslabtech.com

Get a Quote



Get Expert Advice
+658099 5547 (WhatsApp)



Visit Us
www.venuslabtech.com

Overview

Product introduction of VenusLab Scientific sCMOS Camera :

The VenusLab Scientific sCMOS Camera are high-end imaging devices specially designed for cutting-edge scientific research scenarios. They are equipped with a scientific-grade back-illuminated (BSI) CMOS image sensor at their core, integrating deep refrigeration sealing technology and high-speed data transmission technology to achieve a synergistic performance of high sensitivity, high frame rate, high dynamic range, and high signal-to-noise ratio. Their response wavelength range covers 190~1100nm, enabling accurate capture of light signals from ultraviolet to near-infrared. They not only meet the basic research needs in life sciences, quantum physics, astronomical observation, semiconductor testing, etc., but also can be seamlessly integrated into optical detection systems such as structured light microscopes and scanning electron microscopes with their flexible and compact structure, providing reliable solutions for various demanding imaging scenarios.

Features of the VenusLab Scientific sCMOS Camera :

- Multiple interfaces and transmission flexibility
- Lightweight and compact structure
- Wide exposure time range
- Multi-mode readout adaptation
- Standardized compatibility

Dimensions of VenusLab Scientific sCMOS Camera:

VL-4.2 Dimension Drawing

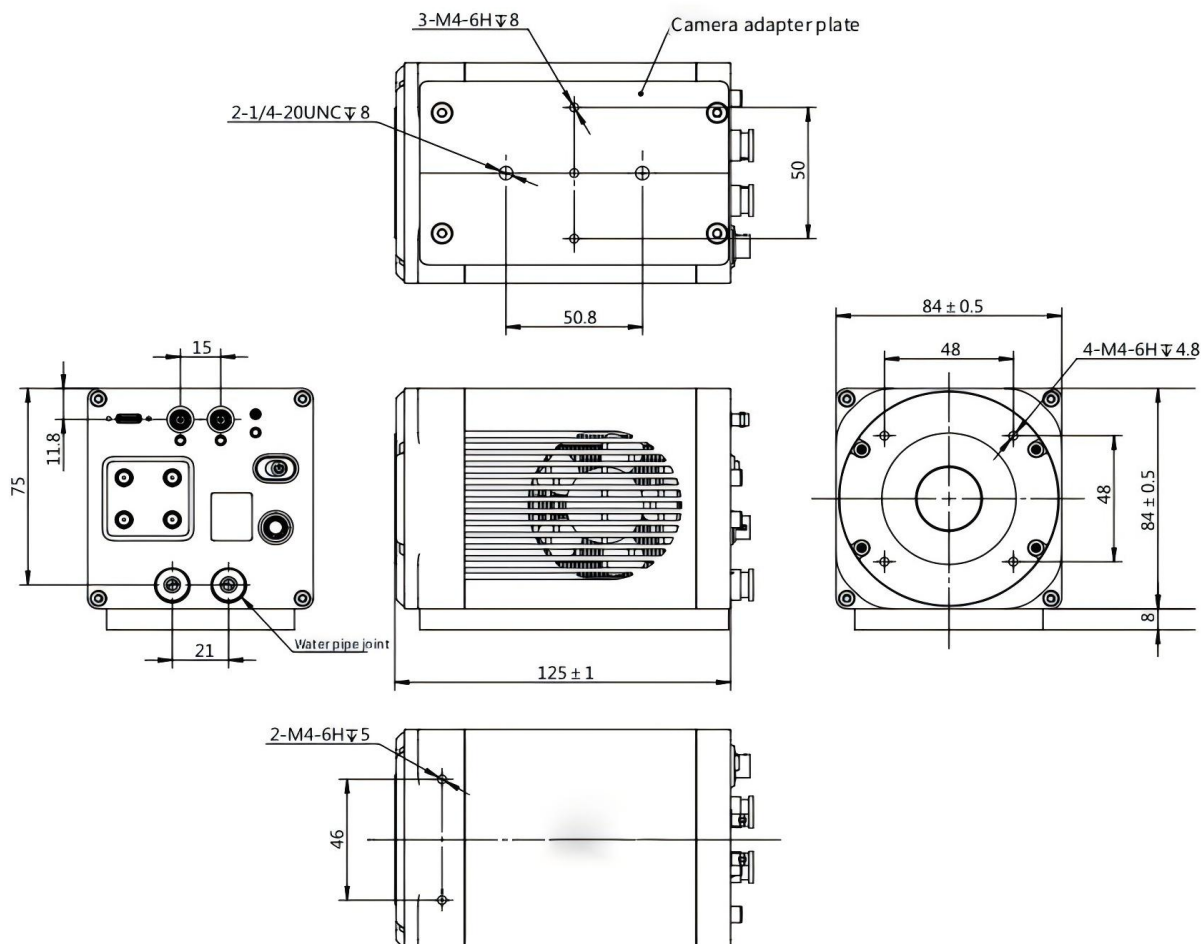

VL-16 Dimension Drawing

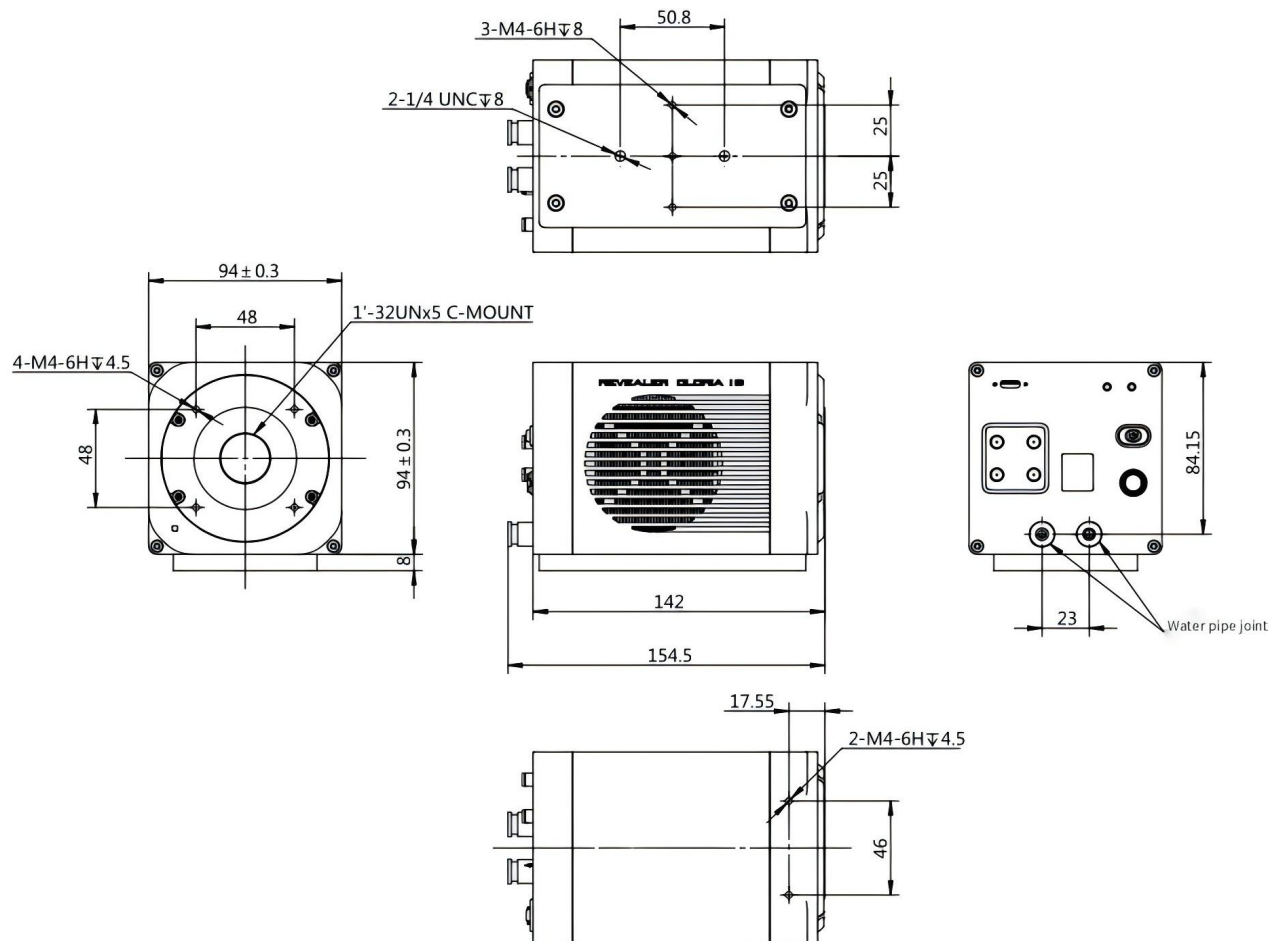

Specifications

VL-4.2, VL-16, VL-95 have the same parameters :

Parameter Name	Parameter Details
Sensor Type	Scientific Backside Illuminated CMOS
Dynamic Range	90 dB
Dark Signal Non-Uniformity	0.2 e ⁻
Photo Response Non-Uniformity	< 0.5% Half Saturation and Step Response
Shutter Type	Rolling
Bit Depth	Multi-mode supported (Gloria 4.2: 11 bit & 12 bit & 16 bit; Gloria 16/95: 12 bit & 16 bit)
Readout Mode	Full Frame / Binning (2x2,4x4) / Region of Interest (ROI)
Data Interface	USB 3.1 Gen1 (Gloria 4.2 additionally supports CoaXPRESS 2.0 (CXP-12))
Timestamp Precision	1 μs
External Trigger Interface	SMA, TTL/3.3V Level
Power Supply	AC 100-240V, 50 Hz / 60 Hz, 1A
Operating Environment	0~40°C, Humidity: 10~80 %
Storage Environment	0~40°C, Humidity: 90%
SDK	C, C#, C++, Python
Software	RPC, Micro-manager, Labview, Matlab, Spim, ASCOM

Application

Cell Biology

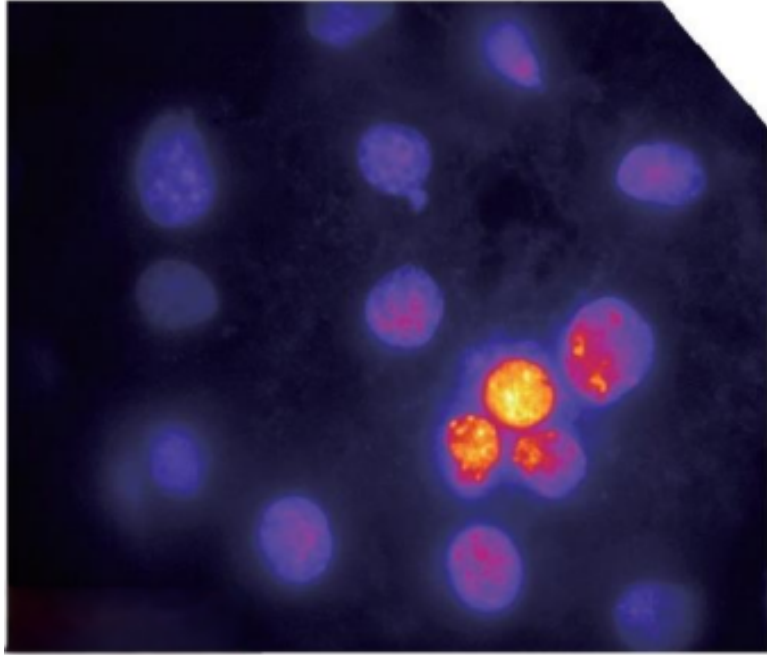

Neurobiology

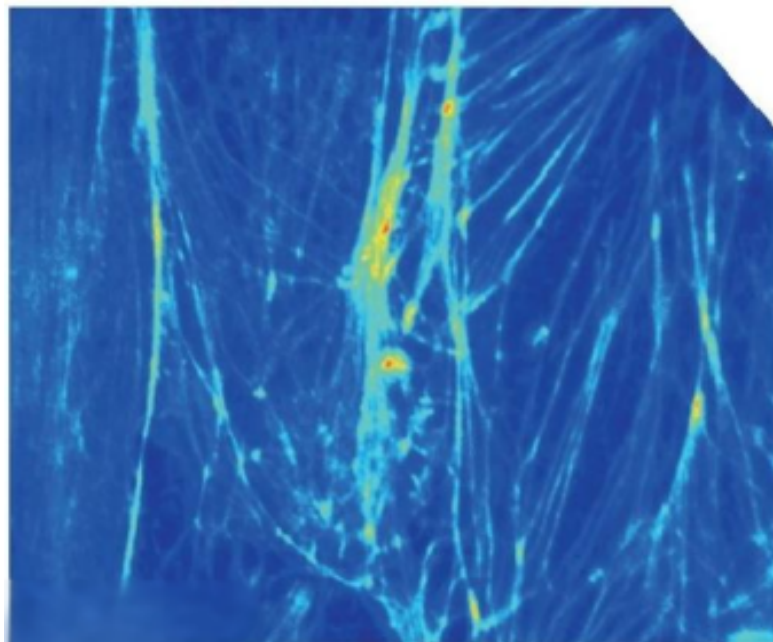

Intracellular Transport

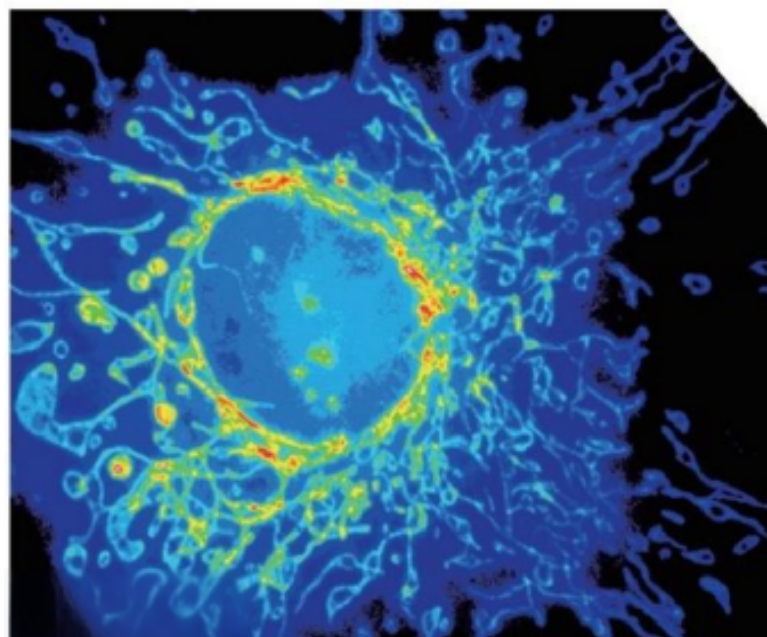

Service & Support

We are dedicated to delivering exceptional optoelectronic solutions to every client. From precision manufacturing and secure delivery to full-lifecycle technical support, we are here to ensure a seamless and reliable experience at every step.

1. Warranty Policy

Quality First, Worry-Free Operation

Warranty Period: We offer a **two-year** warranty service for all of our core optoelectronic products, effective from the date of shipment.

Coverage: We provide free repair or replacement services for malfunctions caused by material defects or workmanship errors under normal operating conditions.

Rapid Response: Upon receiving a warranty claim, we guarantee to initiate the assessment process within **24 hours** to minimize your equipment downtime.

2. Technical Support

Expert Team, Full-Process Guidance

Technical Consultation: Our team of senior optical engineers provides **24/7 online support** to assist with installation, commissioning, optical path alignment, and parameter optimization.

Scheduled Maintenance: We offer full-lifecycle maintenance recommendations, including firmware upgrades, optical component cleaning guidelines, and precision calibration services.

Training Services: We provide customized remote or on-site operational and safety training to ensure your team can operate the equipment efficiently and safely.

3. Logistics & Delivery

Precision Packaging, Global Reach

Professional Packaging: Given the fragile nature of optical instruments, we utilize industrial-grade shockproof, anti-static, and moisture-proof vacuum packaging to ensure zero damage during transit.

Logistics Partners: We partner with top-tier global logistics providers (**DHL / FedEx / UPS / SF Express**) to offer reliable shipping with real-time tracking.

Shipping Insurance: All shipments are fully insured to eliminate logistics risks.

4. Compliance & Certification

Strict Standards, Total Compliance

Quality Certification: Our manufacturing process is **ISO 9001 certified**, and our products comply with international standards such as **CE** and **RoHS**.

Export Compliance: "Committed to environmental responsibility, all our products comply with **RoHS 2.0** and **REACH** standards, ensuring safety and global compliance."

Explore Series

Model	Sensitive Area	Dimension	Cooling Function	Weight
VL-4.2	13.3 mm×13.3 mm	84×84×125 mm	Maximum Cooling Delta Below Ambient 45°C	1300 g
VL-16	12.8 mm×9.6 mm	94×94×142 mm	Maximum Cooling Delta Below Ambient 60°C	1500 g
VL-95	22.5mm×22.5mm	100×100×140 mm	Maximum Cooling Delta Below Ambient 45°C	1600 g

 Get in touch with our team to explore configurations, request a quote, or learn more about customized solutions tailored to your needs.

Let us help you move science forward—faster and smarter.

[Get a Quote](#)



Get Expert Advice
+658099 5547 (WhatsApp)



Visit Us
www.venuslabtech.com