

# Photodiodes

## UV-enhanced Silicon PIN Photodiode (TO Package)

Optoelectronic conversion device with TO transistor package and metal hermetic sealing

- Metal hermetic packaging, stable over a wide temperature range
- High-sensitivity optimization in the ultraviolet band
- Low noise and fast response
- Industrial-grade environmental tolerance
- Flexible adaptation of glass/quartz windows

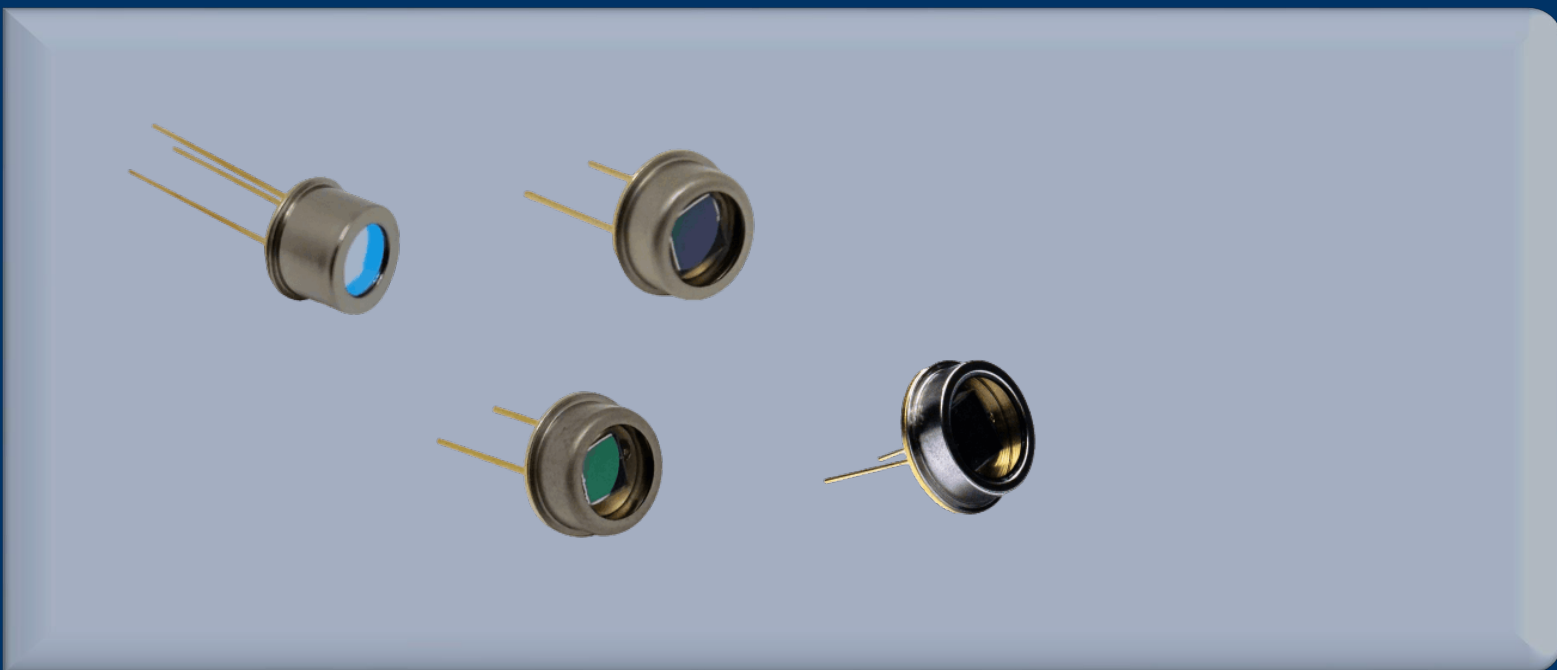

One Platform Many Possibilities

Contact Us [sales@venuslabtech.com](mailto:sales@venuslabtech.com)

Get a Quote



Get Expert Advice  
+658099 5547 ( WhatsApp )



Visit Us  
[www.venuslabtech.com](http://www.venuslabtech.com)

## Overview

### Introduction:

TO-packaged ultraviolet-enhanced Si photodiodes with a spectral response of 250~1060nm, low dark current, low junction capacitance, and optimized ultraviolet response, suitable for optical power detection and optical analysis equipment.

It efficiently captures ultraviolet light signals while being compatible with the inherent near-infrared band (700~1100nm) response capability of silicon-based devices, meeting the requirements of direct plug-in circuit installation in industrial, laboratory and other scenarios.

### Features:

- Metal packaging for dust and moisture protection and anti-aging
- Window core alignment for high-precision and suitable analysis
- Metal shell with excellent heat dissipation and low dark drift

### Dimension:

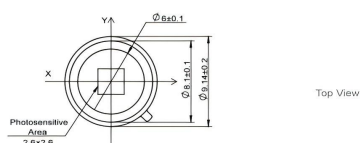

Top View

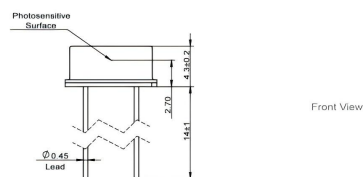

Front View

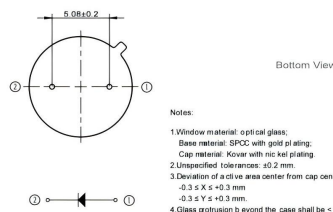

Bottom View

Notes:  
 1.Window material: optical glass;  
 Base material: SPCC with gold plating;  
 Cap material: Kovar with nic kel plating;  
 2.Unspecified tolerances: ±0.2 mm;  
 3.Deviation of a olive area center from cap center:  
 -0.3 ≤ X ≤ +0.3 mm;  
 -0.3 ≤ Y ≤ +0.3 mm;  
 4.Glass protrusion beyond the case shall be < 0.2 mm.

PDCT07-601

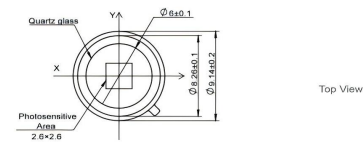

Top View

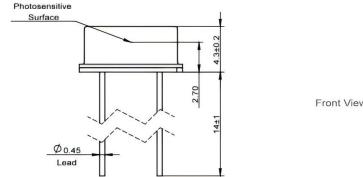

Front View

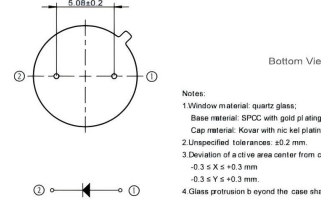

Bottom View

Notes:  
 1.Window material: quartz glass;  
 Base material: SPCC with gold plating;  
 Cap material: Kovar with nic kel plating;  
 2.Unspecified tolerances: ±0.2 mm;  
 3.Deviation of a olive area center from cap center:  
 -0.3 ≤ X ≤ +0.3 mm;  
 -0.3 ≤ Y ≤ +0.3 mm;  
 4.Glass protrusion beyond the case shall be < 0.2 mm.

PDCT07-602

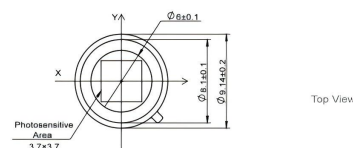

Top View

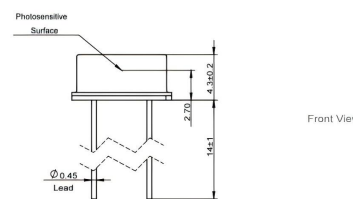

Front View

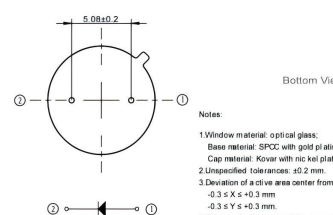

Bottom View

Notes:  
 1.Window material: optical glass;  
 Base material: SPCC with gold plating;  
 Cap material: Kovar with nic kel plating;  
 2.Unspecified tolerances: ±0.2 mm;  
 3.Deviation of a olive area center from cap center:  
 -0.3 ≤ X ≤ +0.3 mm;  
 -0.3 ≤ Y ≤ +0.3 mm;  
 4.Glass protrusion beyond the case shall be < 0.2 mm.

PDCT14-601

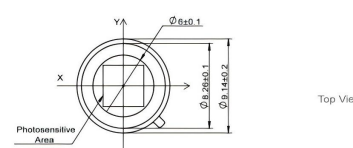

Top View

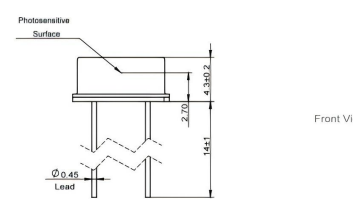

Front View

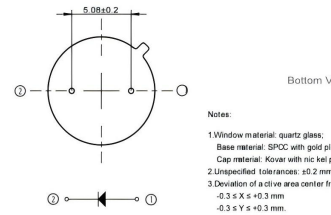

Bottom View

Notes:  
 1.Window material: quartz glass;  
 Base material: SPCC with gold plating;  
 Cap material: Kovar with nic kel plating;  
 2.Unspecified tolerances: ±0.2 mm;  
 3.Deviation of a olive area center from cap center:  
 -0.3 ≤ X ≤ +0.3 mm;  
 -0.3 ≤ Y ≤ +0.3 mm;  
 4.Glass protrusion beyond the case shall be < 0.2 mm.

PDCT14-602

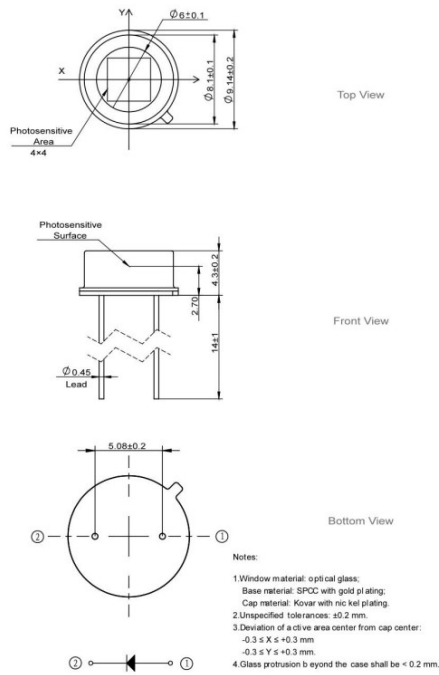

PDCT16-601

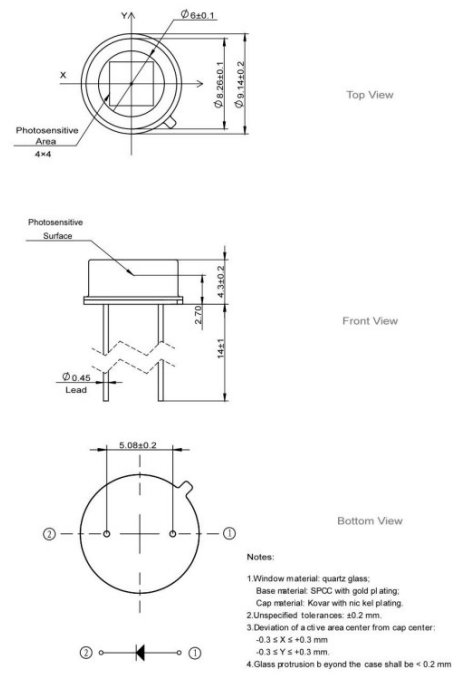

PDCT16-602

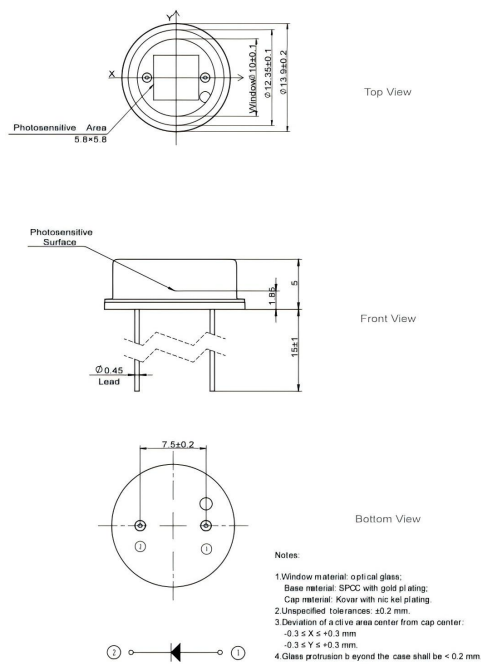

PDCT34-701

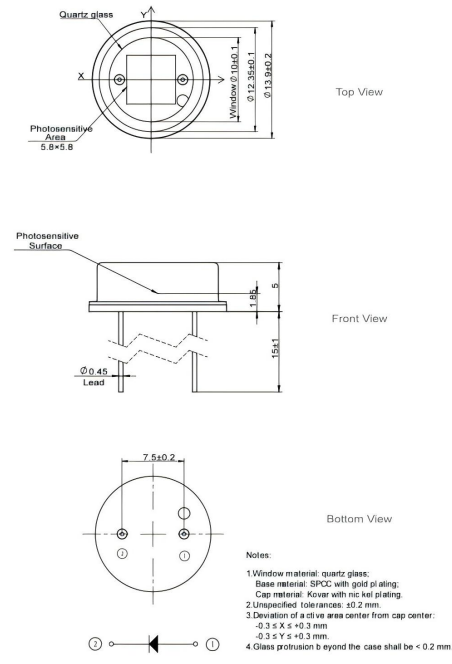

PDCT34-702

## Specifications

### Common Parameter Specification Table

Core Parameter Name	Parameter Value
Package Type	TO Package (Including TO5, TO8)
Pin Count	2pin
Storage Temperature ( )	-55 to +125 (No Condensation)
Operating Temperature ( )	-40 to +100 (No Condensation)
Soldering Temperature ( )	(10s) 260
Maximum Reverse Voltage (V)	20
HBM Mode ESD Protection (V)	1000
Peak Response Wavelength (nm)	800

## Applications

### Spectral response

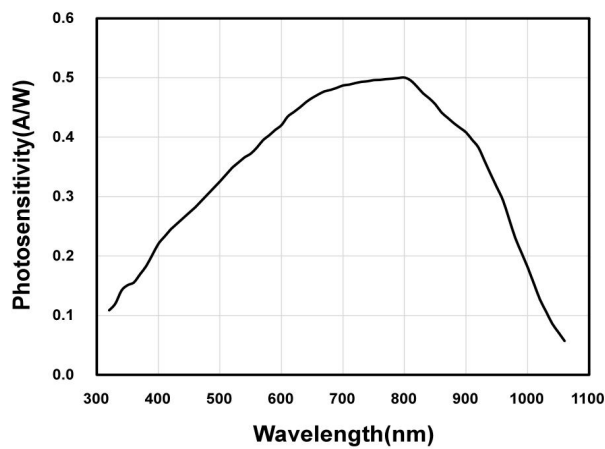

Corresponding product - Optical glass window

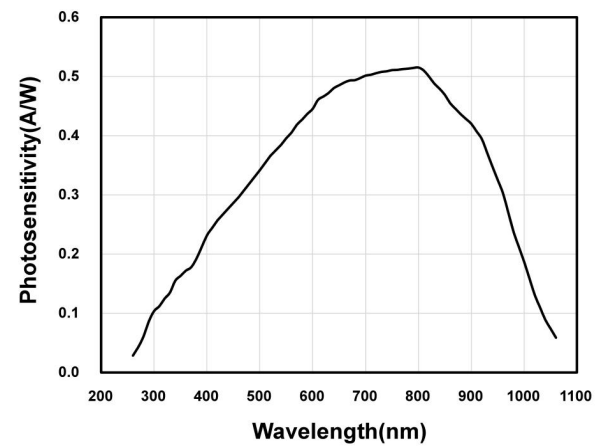

Corresponding product - Quartz window

### Dark current vs. reverse voltage

### Junction capacitance vs. reverse voltage

### Photosensitivity temperature characteristic

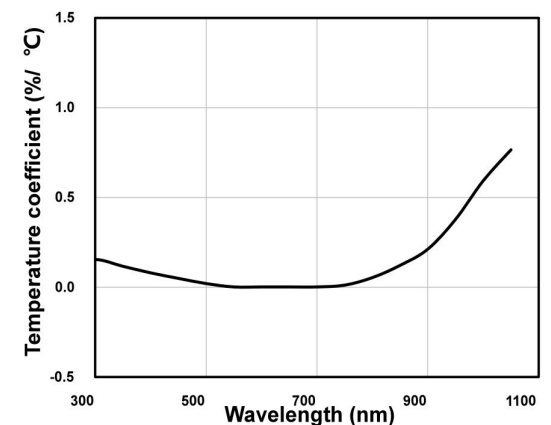
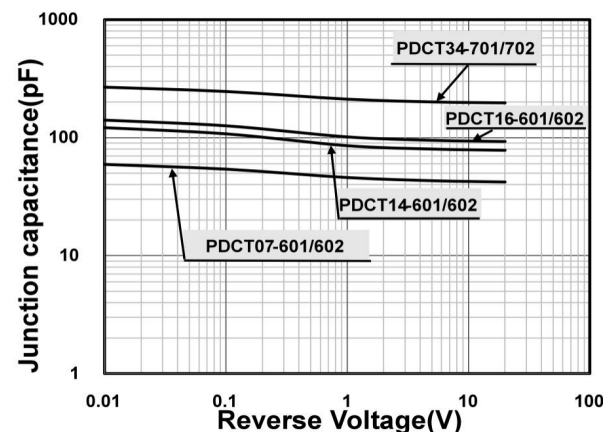
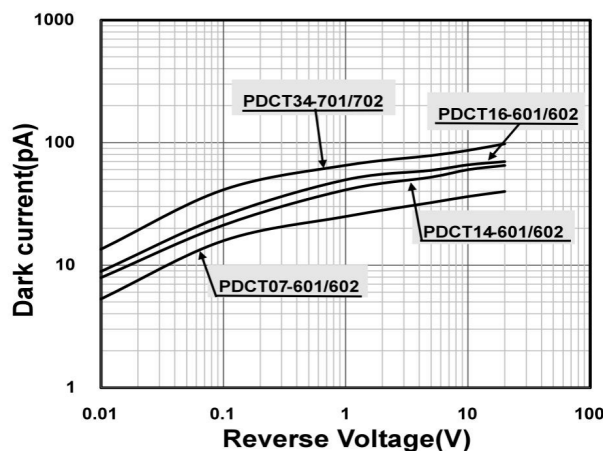

## Explore Series

Model	Dark Current (Max, pA)	Window Material	Photosensitive Area Size (mm)	Junction Capacitance (Max, pF)	Equivalent Noise Power (W/Hz <sup>1/2</sup> )	Spectral Response Range (nm)
PDCT07-601	30	Optical Glass/Flat Window	2.6x2.6	80	$6.1 \times 10^{-15}$	320~1060
PDCT07-602	30	Quartz/Flat Window	2.6x2.6	80	$6.0 \times 10^{-15}$	250~1060
PDCT14-601	50	Optical Glass/Flat Window	3.7x3.7	150	$7.7 \times 10^{-15}$	320~1060
PDCT14-602	50	Quartz/Flat Window	3.7x3.7	150	$7.6 \times 10^{-15}$	250~1060
PDCT16-601	60	Optical Glass/Flat Window	4x4	200	$8.6 \times 10^{-15}$	320~1060
PDCT16-602	60	Quartz/Flat Window	4x4	200	$8.5 \times 10^{-15}$	250~1060
PDCT34-701	90	Optical Glass/Flat Window	5.8x5.8	400	$1.1 \times 10^{-14}$	320~1060
PDCT34-702	90	Quartz/Flat Window	5.8x5.8	400	$1.0 \times 10^{-14}$	250~1060

 Get in touch with our team to explore configurations, request a quote, or learn more about customized solutions tailored to your needs.

Let us help you move science forward—faster and smarter.

[Get a Quote](#)



Get Expert Advice  
+658099 5547 (WhatsApp)



Visit Us  
[www.venuslabtech.com](http://www.venuslabtech.com)