

Ball Screw Turntable

VenusLab-R-M-Series

High-precision displacement control component

- High-precision and stable rotation: $\leq \pm 5$ arcseconds positioning, rigid structure for stable operation
- Multi-adaptability: supports 360°/limited rotation, suitable for heavy loads/special environments

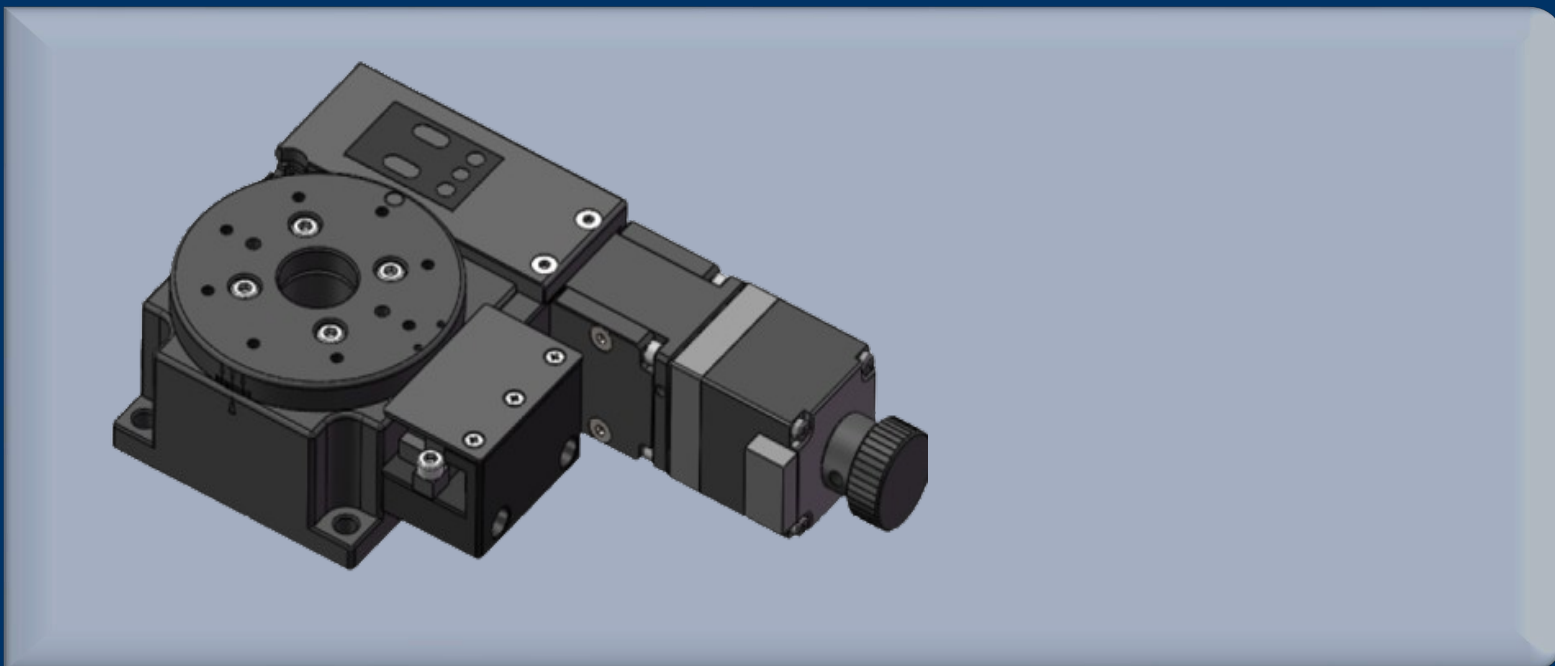

One Platform Many Possibilities

Contact Us sales@venuslabtech.com

Get a Quote



Get Expert Advice
+658099 5547 (WhatsApp)



Visit Us
www.venuslabtech.com

Overview

Multi-working-condition precision electric rotary stage

The VenusLab-R-M Series is a multi-condition precision electric rotary stage from VenusLab, with "high-precision stable rotation + full-range adaptation" as its core. It covers scientific research and industrial scenarios. The product has a repeat positioning accuracy of ± 5 arcseconds, runs stably without jitter, is compatible with 360°/limited rotation, and is suitable for medium and heavy loads as well as special working conditions, providing a reliable solution for multi-dimensional rotation needs.

Features of VenusLab-R-M Series

- The rotating shaft is precision-machined, enabling heavy load bearing and durability.
- High-precision ball screws ensure smooth small-angle positioning.
- The transmission is wear-resistant, maintaining stability after long-term use.
- The tabletop features laser scales for convenient reading.

Service & Support

We are dedicated to delivering exceptional optoelectronic solutions to every client. From precision manufacturing and secure delivery to full-lifecycle technical support, we are here to ensure a seamless and reliable experience at every step.

1. Warranty Policy

Quality First, Worry-Free Operation

Warranty Period: We offer a **two-year** warranty service for all of our core optoelectronic products, effective from the date of shipment.

Coverage: We provide free repair or replacement services for malfunctions caused by material defects or workmanship errors under normal operating conditions.

Rapid Response: Upon receiving a warranty claim, we guarantee to initiate the assessment process within **24 hours** to minimize your equipment downtime.

2. Technical Support

Expert Team, Full-Process Guidance

Technical Consultation: Our team of senior optical engineers provides **24/7 online support** to assist with installation, commissioning, optical path alignment, and parameter optimization.

Scheduled Maintenance: We offer full-lifecycle maintenance recommendations, including firmware upgrades, optical component cleaning guidelines, and precision calibration services.

Training Services: We provide customized remote or on-site operational and safety training to ensure your team can operate the equipment efficiently and safely.

3. Logistics & Delivery

Precision Packaging, Global Reach

Professional Packaging: Given the fragile nature of optical instruments, we utilize industrial-grade shockproof, anti-static, and moisture-proof vacuum packaging to ensure zero damage during transit.

Logistics Partners: We partner with top-tier global logistics providers (**DHL / FedEx / UPS / SF Express**) to offer reliable shipping with real-time tracking.

Shipping Insurance: All shipments are fully insured to eliminate logistics risks.

4. Compliance & Certification

Strict Standards, Total Compliance

Quality Certification: Our manufacturing process is **ISO 9001 certified**, and our products comply with international standards such as **CE** and **RoHS**.

Export Compliance: "Committed to environmental responsibility, all our products comply with **RoHS 2.0** and **REACH** standards, ensuring safety and global compliance."

Explore Series

Model	Tabletop Size	Runout Accuracy	Load (Table/Center)	Weight
VL-R-M6014	φ60mm	-	6kg (Center)	1kg

 Get in touch with our team to explore configurations, request a quote, or learn more about customized solutions tailored to your needs.

Let us help you move science forward—faster and smarter.

[Get a Quote](#)



Get Expert Advice
+658099 5547 (WhatsApp)



Visit Us
www.venuslabtech.com