

Fiber Spectrometers

CloudSense IoT Spectrometer

Industrial-grade miniature fiber optic spectrometer

- High-speed acquisition
- High resolution and low stray light
- Industrial-grade stability
- Convenient data transmission and IoT architecture

Applications: Remote water quality monitoring, smart agriculture, and distributed environmental sensing.

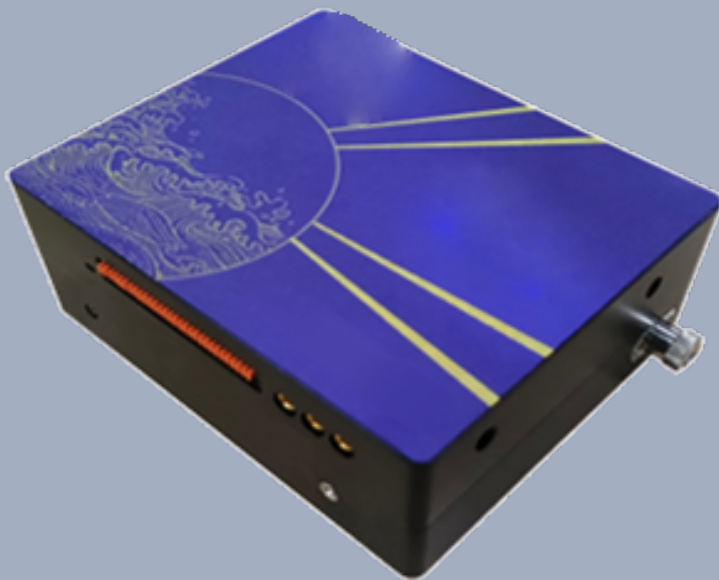

One Platform Many Possibilities

Contact Us sales@venuslabtech.com

Get a Quote



Get Expert Advice
+658099 5547 (WhatsApp)



Visit Us
www.venuslabtech.com

Overview

Introduction to CloudSense IoT Spectrometer :

The ultraviolet high-sensitivity back-illuminated linear array CMOS detector has 2048/4096 optional spectral channels, which can meet detection tasks with different precision requirements. This detector has a good response to ultraviolet light, with a minimum wavelength of 180nm, and can capture weak spectral signals in the deep ultraviolet band. It is suitable for the detection of substances sensitive to ultraviolet light. In the field of industrial manufacturing, it is used for on-site composition analysis of steel furnaces, monitoring of semiconductor plasma etching, etc.; in terms of environmental monitoring, it can real-time detect water/atmospheric pollutants and screen for heavy metals in soil; in the field of life sciences, it helps in the research of biomolecular dynamics and the analysis of drug excited states; in the intelligent quality inspection process, it can detect food additives, identify the authenticity of three-way catalytic converters and other scenarios.

Specifications

Pre-Configured Fiber Optic Spectrometer Selection Chart

Product Code	Spectral Scope:		Spectral resolution:	
	Starting wavelength	Cutoff wavelength	Minimum resolution	Typical resolution
VLIoT-200-1100	200	1100	0.8	1.0
VLIoT-200-800	200	800	0.6	0.8
VLIoT-350-970	350	970	0.6	0.8

*1. Minimum resolution is 10um at the slit;*2. Specific models require a defined slit, e.g. Gino-200-1100 is a 25um slit configuration;*3. Large slits are available for high sensitivity requirements, with slits of 10um/ 25um/ 50um/ 100um/ 200um/ 300um/ 500um available;

Interface Definition

Interface description

The diagram below shows the various interfaces of the CloudSense IoT Spectrometer. The 1000M RJ-45 Ethernet port is used for data transmission, while the HDMI port allows for connection to an external display. The USB 2.0 HOST port supports external devices such as a keyboard or mouse. The 15-pin interface is for secondary development of the spectrometer, and the three MMCX interfaces are used for external triggering.

Definition of the wiring pin

The 24pin port uses a 2.0MM-24P socket.

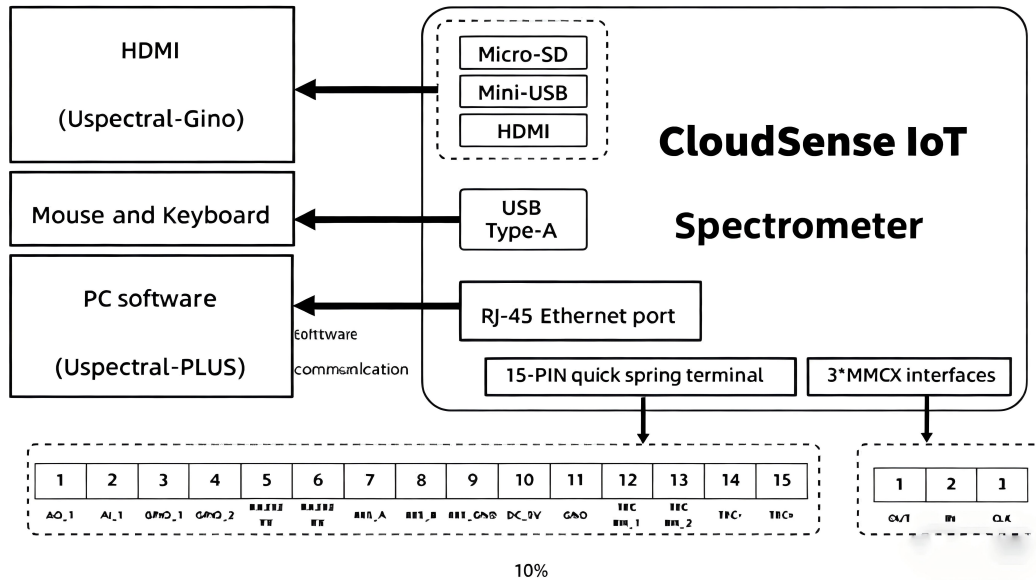

The 15-pin interface uses a 15-pin quick spring terminal.

1	DAC1 Output
2	ADC1 Input
3	IO1 Output 3.3V/0V Configurable
4	IO2 Output 3.3V/0V Configurable
5	TTL/232 UART_TX
6	TTL/232 UART_RX
7	485A
8	485B
9	Power Ground
10	Power 5V Input
11	Signal Ground
12	NTC Feedback Negative
13	NTC Feedback Positive
14	NTC Feedback Positive
15	TEC Output Positive

Dimensional drawing

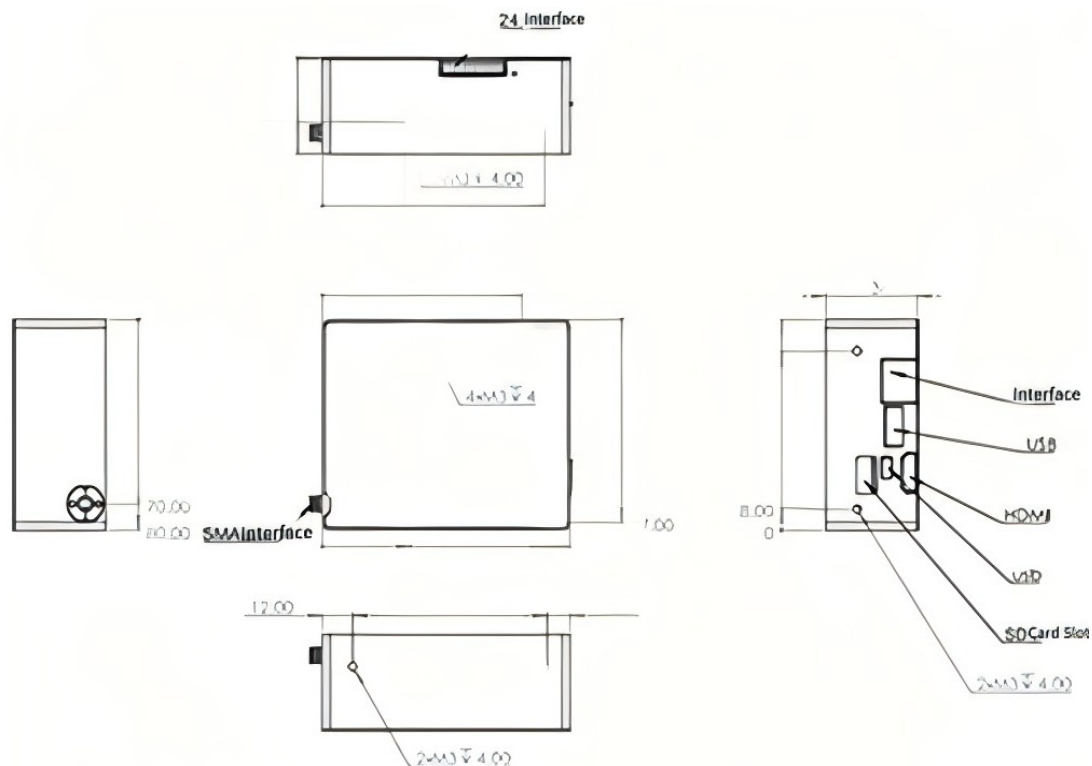

Typical Spectrum

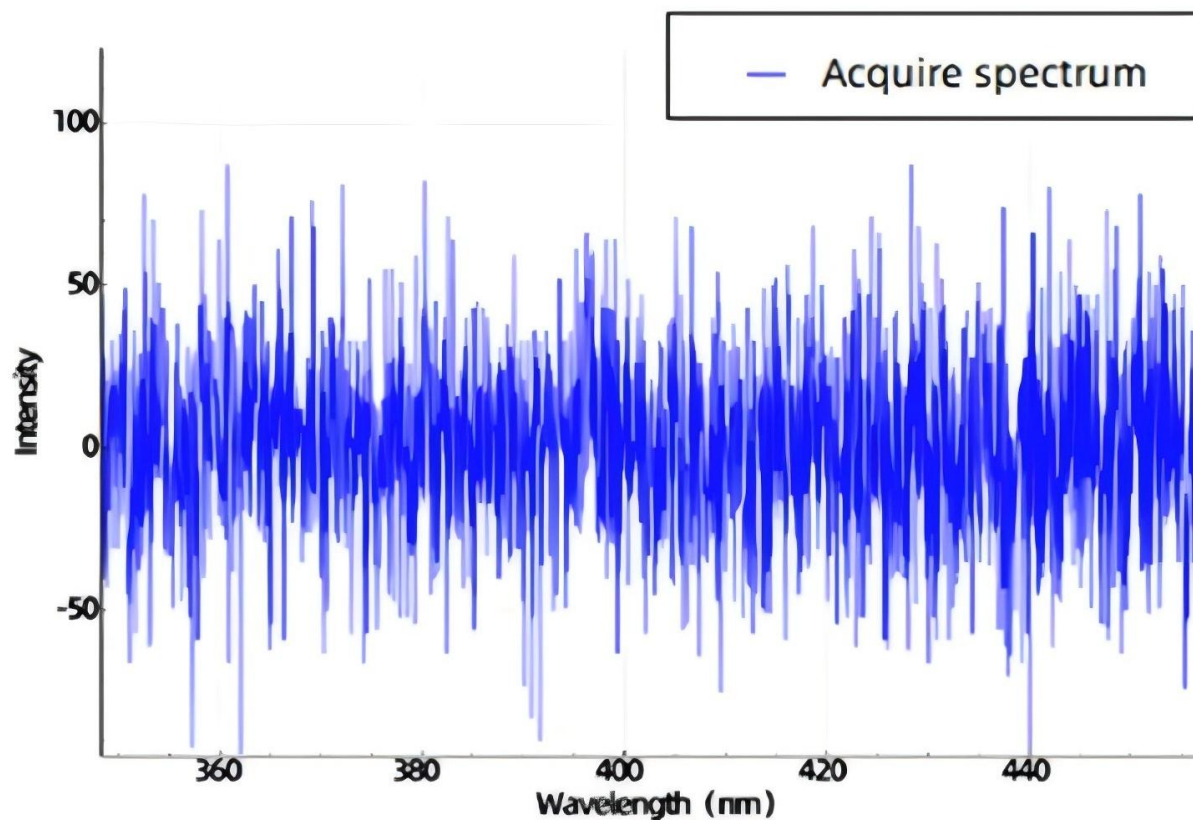

Service & Support

We are dedicated to delivering exceptional optoelectronic solutions to every client. From precision manufacturing and secure delivery to full-lifecycle technical support, we are here to ensure a seamless and reliable experience at every step.

1. Warranty Policy

Quality First, Worry-Free Operation

Warranty Period: We offer a **two-year** warranty service for all of our core optoelectronic products, effective from the date of shipment.

Coverage: We provide free repair or replacement services for malfunctions caused by material defects or workmanship errors under normal operating conditions.

Rapid Response: Upon receiving a warranty claim, we guarantee to initiate the assessment process within **24 hours** to minimize your equipment downtime.

2. Technical Support

Expert Team, Full-Process Guidance

Technical Consultation: Our team of senior optical engineers provides **24/7 online support** to assist with installation, commissioning, optical path alignment, and parameter optimization.

Scheduled Maintenance: We offer full-lifecycle maintenance recommendations, including firmware upgrades, optical component cleaning guidelines, and precision calibration services.

Training Services: We provide customized remote or on-site operational and safety training to ensure your team can operate the equipment efficiently and safely.

3. Logistics & Delivery

Precision Packaging, Global Reach

Professional Packaging: Given the fragile nature of optical instruments, we utilize industrial-grade shockproof, anti-static, and moisture-proof vacuum packaging to ensure zero damage during transit.

Logistics Partners: We partner with top-tier global logistics providers (**DHL / FedEx / UPS / SF Express**) to offer reliable shipping with real-time tracking.

Shipping Insurance: All shipments are fully insured to eliminate logistics risks.

4. Compliance & Certification

Strict Standards, Total Compliance

Quality Certification: Our manufacturing process is **ISO 9001 certified**, and our products comply with international standards such as **CE** and **RoHS**.

Export Compliance: "Committed to environmental responsibility, all our products comply with **RoHS 2.0** and **REACH** standards, ensuring safety and global compliance."

Explore Series

ModelSpectral	Resolution(25µm)	Spectral Region(nm)
VLIoT-200-1100	1.00	200-1100
VLIoT-200-800	0.80	200-800
VLIoT-350-970	0.80	350-970

 Get in touch with our team to explore configurations,request a quote,or learn more about customized solutions tailored to your needs.

Let us help you moves cience forward—faster and smarter.

[Get a Quote](#)



Get Expert Advice
+658099 5547 (WhatsApp)



Visit Us
www.venuslabtech.com